



SERVICE INFORMATION

BOOTH EQUIPMENT

Each 8' x 10' booth will be set up with 8' high black back drape, 3' high black side dividers, (1) 6' L x 30" H x 24" W black draped table, (2) side chairs, and (1) wastebasket. Booths 300 sqft or less will receive a one-line identification sign. Booths larger than 300 sqft may receive a one-line identification sign upon request.

EXHIBIT HALL CARPET

The exhibit area is carpeted. Exhibitors will be permitted to install different color carpet at their expense. To enhance the appearance of your booth, rental carpet is available through Freeman. Please refer to the Carpet Brochure and Order Form located in this manual.

DISCOUNT PRICE DEADLINE DATE

Order early to take advantage of advance order discount rates, place your order by October 14, 2016.

SHOW SCHEDULE

EXHIBITOR MOVE-IN

For more information and helpful hints on pre-show procedures and move-in, please go to www.freemanco.com/preshowFAQ

Friday November 04, 2016 7:00 AM - 11:00 AM

EXHIBIT HOURS

Friday November 04, 2016 11:00 AM - 9:00 PM
Saturday November 05, 2016 7:00 AM - 5:00 PM

EXHIBITOR MOVE-OUT

For more information and helpful hints on post-show procedures and move-out, please go to www.freemanco.com/postshowFAQ

Saturday November 05, 2016 5:00 PM - 10:00 PM

We will begin returning empty containers at the close of the show.

DISMANTLE AND MOVE-OUT INFORMATION

All exhibitor materials must be removed from the exhibit facility by Saturday, November 05, 2016 at 10:00 PM.

To ensure all exhibitor materials are removed from the exhibit facility by the Exhibitor Move-Out deadline, please have all carriers check-in by Saturday, November 05, 2016 at 8:00 PM.

POST SHOW PAPERWORK AND LABELS

Our Exhibitor Services Department will gladly prepare your outbound Material Handling Agreement and labels in advance. Be sure your carrier knows the company name and booth number when making arrangements for shipping your exhibit at the close of the show.

SERVICE CONTRACTOR CONTACTS / INFORMATION:

FREEMAN

841 Joseph E Lowery Blvd NW
Atlanta, GA 30318
(404) 253-6494 fax (469) 621-5610
FreemanAtlantaES@freemanco.com

FREEMAN EXHIBIT TRANSPORTATION

(800) 995-3579 US & Canada or +1(512) 982-4187 Outside the US or +1(817) 607-5183
International Shipping Services or fax (469) 621-5810 or email exhibit.transportation@freemanco.com

FREEMAN ONLINE®

Take advantage of discount pricing by ordering online at www.freemanco.com/store by October 14, 2016. Using the enhanced Freeman Online, you will enjoy easy access to added features and functions as well as the high caliber of Freeman services you've come to expect — **before, during and after** your show. Additionally, you can now access FreemanOnline from any device — **desktop, laptop, tablet** or via our new **Freeman Online Mobile App**.

To place online orders, you will be required to enter your unique Username and Password. If this is your first time to use Freeman Online, click on the "Create an Account" link. To access Freeman Online without using the email link, visit www.freemanco.com/store. You can also download and use the FOL Mobile App from the Apple or Android store, or here: folmobile.freemanco.com. A mobile web version of the Freeman Online Mobile App is available to extend mobile use for those users that do not have an Apple or Android device or who do not want to download the app.

If you need assistance with Freeman Online, please call our Customer Support Center at (888) 508-5054 Toll Free US and Canada or +1(512) 982-4186 Local and International.

SHIPPING INFORMATION

Warehouse Shipping Address:

Exhibiting Company Name / Booth #
PFA 57th ANNUAL SYMPOSIUM AND EXPO
C/O Freeman
841 Joseph E Lowery Blvd NW
Atlanta, GA 30318

Freeman will accept crated, boxed or skidded material beginning Wednesday, October 05, 2016 at the above address. Material arriving after October 28, 2016 will be received at the warehouse with an additional after deadline charge. Warehouse materials are accepted at the warehouse Monday through Friday between the hours of 8:00 AM - 4:00 PM. If required, provide your carrier with this phone number: (404) 253-6494.

Please Note: Due to limited storage space and material handling services at the Hotel, all exhibitor freight should be sent to the Freeman Warehouse. If special circumstances require you to ship directly to the Hotel, please call Freeman Exhibitor Services to provide you with the ship to address, instructions, and specific receiving dates.

Freeman will receive shipments at the exhibit facility beginning Friday, November 04, 2016 at 8:00 AM. Shipments arriving before this date may be refused by the facility. Any charges incurred for early freight accepted by the facility will be the responsibility of the exhibitor. If required, provide your carrier with this phone number: (404) 253-6494.

Please note: All items and materials that must be brought into the facility are subject to Material Handling Charges and are the responsibility of the Exhibitor. This also applies to items not ordered through the Official Show Vendors. Refer to the Material Handling form for charges for the service.

LABOR INFORMATION

Union Labor may be required for your exhibit installation and dismantle. Please carefully read the UNION RULES AND REGULATIONS to determine your needs. Exhibitors supervising Freeman labor will need to pick up and release their labor at the Labor Desk. Refer to the order form under Display Labor for Straight time and Overtime hours.

ASSISTANCE

We want you to have a successful show. If we can be of assistance, please call our Exhibitor Services Department at (404) 253-6494.

WE APPRECIATE YOUR BUSINESS!

FREEMAN GENERAL INFORMATION

TRANSLATION SERVICES

Freeman is pleased to offer a new service for our international exhibitors that provides quick interpretation and translation in 150 languages. This service will not only interpret for us on a three way conversation, but also translate emails from customers. To access this feature you may contact Freeman Exhibitor Services at (404) 253-6494 or Freeman's Customer Support Center at (888) 508-5054.

HELPFUL HINTS

SAVE MONEY

Order early to take advantage of advance order discount rates, place your order by October 14, 2016.

AVOID DELAY

Ship early to avoid delays. Shipments arriving late at show site will cost you money, time and business!

SAFETY TIPS

Use a ladder, not a chair. Standing on chairs, tables and other rental furniture is unsafe and can cause injury to you or to others. These objects are not designed to support your standing weight.

Be aware of your surroundings. You are in an active work area with changing conditions during move-in and move-out. Pay attention. Look for obstacles, machinery and equipment that are in use.

Keep your eyes open for scooters and forklifts. The drivers of these vehicles may not be able to see you.

Stay clear of dock areas, trucks and trailers. These areas can be particularly dangerous.

Prevent electrical shocks, falling items and damage to materials. Do not attach items or equipment to the drapes or metal framework provided for your booth. This can cause serious injury or damage to materials.

We discourage children from being in the exhibit hall during installation and dismantle. If children are present during installation and dismantle, they must be supervised by an adult at all times.

Freeman does not ship or handle Hazardous Materials. If any materials you are shipping to the event fall into this category, please contact Freeman to be sure the material will be allowed at the facility and by the association. In addition, if authorized by the facility and the association, you will need to make separate arrangements for the transport and handling of the approved materials, since Freeman will not transport or handle them.

The operation or use of all motorized lifts and motorized material handling equipment for installation/dismantle of exhibits is NOT permitted by exhibitors or by their exhibitor appointed contractors (EAC's). Thank you for your cooperation.

EXHIBITOR ASSISTANCE

For more information and helpful hints on pre-show procedures and move-in, please go to www.freemanco.com/preshowFAQ.

For more information and helpful hints on post-show procedures and move-out, please go to www.freemanco.com/postshowFAQ.

Call Freeman's Exhibitor Services department at (404) 253-6494 with any questions or needs you may have.



Reducing Your Footprint

Freeman actively engages in green practices within day-to-day operations and is committed to producing events in the most environmentally friendly way possible. Freeman has collaborated with a number of customers to make their events greener and is dedicated to broadening this effort.

Green Tips for Exhibitors

Interested in going Green and saving money with your exhibit booth? Follow these tips to assist you in making your sustainable booth strategies at least cost-neutral, and possibly cost-saving!

Supplies and Ordering

- Order exhibit supplies early and utilize online ordering systems to eliminate paper waste.
- Consider renting a booth from Freeman or buying materials locally, preventing shipping cost and lowering emissions.
- Rent Freeman Classic Carpet which contains recycled content and is also recyclable.
- Provide giveaways made of recycled, responsibly grown natural fiber, nontoxic and biodegradable materials. Ensure giveaways are useful, not merely promotional in nature. Electronic Giveaways, such as free songs from iTunes, coupons and free online Apps are smart and trendy.

Printing, Recycling and Waste Management

- Encourage less printing and provide more information digitally when it comes to booth literature, fulfilling requests via email and website referrals.
- If you need to print, use a local printer in the city where the show will be held and choose paper that contains at least 50% post-consumer recycled content.
- Ask Freeman about new paper-based signage materials that are comparably priced to plastic. There are good alternatives to foam core and PVC which are not as easily recyclable.
- Participate in the exhibit donation program by providing materials that are eligible for donation to local charities, such as pens, bags and notepads.

Shipping and Transportation

- If you must ship materials, planning out your booth in a timely way to meet shipping deadlines can also help maximize consolidation and cost-savings.
- Choose a SmartWay™-certified hauler at no additional cost to ensure your transportation company is practicing sustainable shipping.
- Set a goal to leave no trace behind by shipping out all booth properties and packing materials and donating extra giveaways thereby minimizing any waste for the show.
- If you are attending another trade show that many of your fellow exhibitors are also participating in, ask your General Service Contractor or Show Management to set up a caravan service to save on fuel emissions—and cost of transportation.



Personnel and Best Practices

- Take advantage of local or regional representatives to staff your booth, rather than bringing staff from far away offices, reducing travel cost.
- Bring Green as part of your company message providing recycling bins in your booth and information on what you have done to exhibit in a sustainable way.



These steps can help as we all strive to make smarter and more environmentally sound decisions. For more information on the Freeman Sustainability Initiative, contact goinggreen@freemanco.com

F R E E M A N

841 Joseph E Lowery Blvd N W
Atlanta, GA 30318
(404) 253-6494 Fax: (469) 621-5610

DISCOUNT PRICE
DEADLINE DATE
OCTOBER 14, 2016

INCLUDE THIS FORM
WITH YOUR ORDER
PLEASE USE BLACK INK

NAME OF SHOW: **PFA 57TH ANNUAL SYMPOSIUM AND EXPO / NOVEMBER 04 - 05, 2016**

COMPANY NAME: _____ BOOTH #: _____

ADDRESS: _____ BOOTH SIZE : _____ X

CITY/STATE/ZIP: _____

PHONE: _____ EXT.: _____ FAX #: _____

SIGNATURE: _____ PRINT NAME: _____

CONTACT'S E-MAIL: _____

E-MAIL FOR INVOICE: _____ **Check if you are a new Freeman customer**
Invoices will be sent by e-mail; please provide e-mail address of the person who reconciles your invoices if different than contact's email.

METHOD OF PAYMENT

BY SUBMITTING THIS FORM VIA FAX OR POSTAL MAIL OR ORDERING MATERIALS OR SERVICES FROM FREEMAN, YOU AGREE TO BE BOUND BY ALL TERMS & CONDITIONS INCLUDED IN YOUR SERVICE MANUAL.

COMPANY CHECK
 Please make check payable to: Freeman
 Checks must be in U.S. funds drawn on a U.S. or Canadian bank. ("U.S. FUNDS" MUST BE PRE-PRINTED on Canadian checks.)
Please reference (435964) on your remittance.

BANK TRANSFER
 Bank transfer to Bank of America, N.A.; Dallas, TX
Wire Transfer
 ABA#: 026009593 ACCT# 1252039192 Freeman
International Wire Transfer
 Swift Code: BOFAUS3N ACCT# 1252039192 Freeman
ACH Direct Deposit
 ABA#: 111000012 ACCT# 1252039192 Freeman
Please reference Name of Show & Booth Number so we can properly credit your account.
Note: Customers are responsible for any bank processing fees.

CREDIT/DEBIT CARD
 For your convenience, we will use this authorization to charge your credit/debit card account for your advance orders, and any additional amounts incurred as a result of show site orders placed by your representative. These charges may include all Freeman companies, or any charges which Freeman may be obligated to pay on behalf of Exhibitor, including without limitation, any shipping charges. Please complete the information requested below:

AMERICAN EXPRESS **MASTER CARD** **VISA** **FREEMAN NOW ACCEPTS DEBIT CARDS**

ACCOUNT NO.: _____ EXP. DATE: _____

CARDHOLDER NAME (PRINT): _____ SIGNATURE: _____

CARDHOLDER BILLING ADDRESS: _____
 CITY/STATE/ZIP: _____

ENTER TOTALS HERE

FURNISHINGS & ACCESSORIES	CARPET	CLEANING/ SHAMPOOING	PORTER SERVICE	RENTAL EXHIBITS & ACCESSORIES	SIGNS	INSTALLATION LABOR	DISMANTLE LABOR
MATERIAL HANDLING	RIGGING INSTALLATION	RIGGING DISMANTLE	EXHIBIT TRANSPORTATION	HANGING SIGNS	GRAND TOTAL		

- Remember to order in advance to save time and money. You may place your order by phone, fax, mail, or use our online ordering service at: www.freemanco.com/store. **We do not accept credit card information via email.**
- Orders received without payment or after the discount price deadline date will be charged at the standard price.
- Copies of invoices may be picked up from the Service Desk prior to show closing.
- If you have questions or need assistance with any items not listed, please call and ask for your Exhibitor Services Representative.

TELL US WHAT YOU THINK

Freeman is committed to providing great customer service. To help us serve you more effectively in the future, please visit the URL address below upon the completion of your show to provide feedback. Your input will provide the insight needed to ensure that our customer service is in line with your expectations.
<http://feedback.freemanco.com/?435964>

FREEMAN method of payment

F R E E M A N

841 Joseph E Lowery Blvd N W
Atlanta, GA 30318
(404) 253-6494 Fax: (469) 621-5610

PFA 57TH ANNUAL SYMPOSIUM AND EXPO / NOVEMBER 04 - 05, 2016

In order to authorize Freeman to invoice a third party for payment of services rendered to exhibitors, both the exhibiting company and the third party must complete this form and return it at least 14 days prior to show move-in.

EXHIBITING COMPANY AUTHORIZATION OF THIRD PARTY BILLING

"We understand and agree that we, the exhibiting company, are ultimately responsible for payment of charges and agree by submitting this form or ordering materials or services from Freeman, to be bound by all terms and conditions as described in the Terms & Conditions section of this service manual. In the event that the named third party does not discharge payment of the invoice prior to the last day of the show, charges will revert back to the exhibiting company. All invoices are due and payable upon receipt, by either party. The items checked below are to be invoiced to the third party."

BY SUBMITTING THIS FORM VIA FAX OR POSTAL MAIL OR ORDERING MATERIALS OR SERVICES FROM FREEMAN, YOU AGREE TO BE BOUND BY ALL TERMS & CONDITIONS INCLUDED IN YOUR SERVICE MANUAL.

EXHIBITOR NAME: (PLEASE PRINT)

EXHIBITOR SIGNATURE:

DATE:

EXHIBITING COMPANY INFORMATION

EXHIBITING COMPANY NAME:

BOOTH #:

EXHIBITING COMPANY ADDRESS:

CITY/STATE/ZIP:

PHONE:

EXT:

FAX:

CONTACT'S E-MAIL:

Indicate which services are to be invoiced to the Third Party:

- | | |
|---|---|
| <input type="checkbox"/> ALL FREEMAN SERVICES | <input type="checkbox"/> FREEMAN EXHIBIT TRANSPORTATION |
| <input type="checkbox"/> I&D LABOR/SUPERVISION | <input type="checkbox"/> RENTAL FURNITURE/CARPET/SIGNS |
| <input type="checkbox"/> MATERIAL HANDLING/IN & OUT | <input type="checkbox"/> BOOTH CLEANING |
| | <input type="checkbox"/> OTHER _____ |

THIRD PARTY COMPANY INFORMATION

THIRD PARTY COMPANY NAME:

CONTACT NAME:

THIRD PARTY BILLING ADDRESS:

CITY/STATE/ZIP:

PHONE:

EXT:

FAX:

CONTACT'S E-MAIL:

E-MAIL FOR INVOICE:

Invoices will be sent by e-mail; please provide the e-mail address of the person who reconciles your invoices if different than contact's e-mail.

THIRD PARTY CREDIT/DEBIT CARD AUTHORIZATION

AMERICAN EXPRESS MASTERCARD VISA **FREEMAN NOW ACCEPTS DEBIT CARDS**

ACCOUNT NO:

EXP. DATE:

CARDHOLDER NAME (PLEASE PRINT):

CARD TYPE:

AUTHORIZED SIGNATURE:

CARDHOLDER BILLING ADDRESS:

CITY/STATE/ZIP:

07/15 (435964)

third party authorization
FREEMAN

PAYMENT & LABOR

YOU ARE ENTERING A CONTRACT WHICH LIMITS YOUR POSSIBLE RECOVERY IN CASE OF LOSS OR DAMAGE.

The terms and conditions set forth below become a part of the Contract between FREEMAN and you, the EXHIBITOR. Acceptance of said terms and conditions will be construed when any of the following conditions are met:

- THE METHOD OF PAYMENT FORM IS SIGNED; OR
- AN ORDER FOR LABOR, SERVICES AND/OR RENTAL EQUIPMENT IS PLACED BY EXHIBITOR WITH FREEMAN; OR
- WORK IS PERFORMED ON BEHALF OF EXHIBITOR BY LABOR SECURED THROUGH FREEMAN.

DEFINITIONS

For purposes of this Contract, "FREEMAN" or "The Freeman Companies" means Freeman Expositions, Inc., Freeman Expositions, Ltd., Freeman Audio Visual, Freeman Exhibit, Freeman Transportation, Hoffend Xposition, Stage Rigging, Inc., Kerry Technical Services, TFC, Inc., Freeman Electrical Services, and their respective employees, directors, officers, agents, assigns, affiliated companies, and related entities including, but not limited to, any subcontractors FREEMAN may appoint. The term "EXHIBITOR" means the Exhibitor, its employees, agents, representatives, and any Exhibitor Appointed Contractors ("EAC").

PAYMENT TERMS

Full payment, including any applicable tax, is due in advance or at show site. All payments must be in U.S. funds and all checks must be drawn on a U.S. bank. Orders received without advance payment or after the deadline date will incur additional After Deadline charges as indicated on each order form. All materials and equipment are on a rental basis for the duration of the show or event and remain the property of FREEMAN except where specifically identified as a sale. All rentals include delivery, installation, and removal from EXHIBITOR'S booth. In case of cancellation of any orders or services by EXHIBITOR, a one-hour "per person, per hour" charge will be applied for all labor orders that are not canceled in writing at least 24 hours prior to the scheduled start time. If Prestige Carpet, Custom-Cut Carpet, Modular Rental Exhibits and any other custom-order items or services have already been provided at the time of cancellation, fees will remain at 100% of the original charge. If the Show or Event is canceled because of reasons beyond FREEMAN'S control, EXHIBITOR remains responsible for all charges for services and equipment provided up to and including the date of cancellation. FREEMAN will not issue refunds to EXHIBITOR of any payments made before the date of cancellation. It is EXHIBITOR'S responsibility to advise the FREEMAN Service Center Representative of problems with any orders, and to check the EXHIBITOR'S invoice for accuracy prior to the close of the Show or Event. If EXHIBITOR is exempt from payment of sales tax, FREEMAN requires an exemption certificate for the State in which the services are to be used. Resale certificates are not valid unless EXHIBITOR is rebilling these charges to its customers. For International EXHIBITORS, FREEMAN requires 100% prepayment of advance orders, and any order or services placed at show site must be paid at the show. For all others, should there be any pre-approved unpaid balance after the close of the show; terms will be net, due and payable in DALLAS, TEXAS upon receipt of invoice. Effective 30 days after invoice date, any unpaid balance will bear a FINANCE CHARGE at the lesser of the maximum rate allowed by applicable law, or 1.5% per month, which is an ANNUAL PERCENTAGE RATE of 18%, and future orders will be on a prepaid basis only. If any finance charge hereunder exceeds the maximum rate allowed by applicable law, the finance charge shall automatically be reduced to the maximum rate allowed, and any excess finance charge received by FREEMAN shall be either applied to reduce the principal unpaid balance or refunded to the payer. If past due invoices or invoice balances are placed with a collection agency or attorney for collection or suit, EXHIBITOR agrees to pay all legal and collection costs. THESE PAYMENT TERMS AND CONDITIONS SHALL BE GOVERNED BY AND CONSTRUED IN ACCORDANCE WITH THE LAWS OF THE STATE OF TEXAS. In the event of any dispute between the EXHIBITOR and FREEMAN relative to any loss, damage, or claim, such EXHIBITOR shall not be entitled to and shall not withhold payment, or any partial payment, due to FREEMAN for its services, as an offset against the amount of any alleged loss or damage. Any claims against FREEMAN shall be considered a separate transaction, and shall be resolved on its own merits. FREEMAN reserves the right to charge EXHIBITOR for the difference between the EXHIBITOR'S estimate of charges and the actual charges incurred by EXHIBITOR, or for any charges that FREEMAN may be obligated to pay on behalf of EXHIBITOR, including without limitation, any shipping charges. If EXHIBITOR provides a credit card for payment and charges are rejected by the EXHIBITOR'S credit card company for any reason, FREEMAN hereby provides notice that it reserves the right, and EXHIBITOR authorizes FREEMAN, to continue to attempt to secure payment through that credit card for as long as unpaid balances remain on the EXHIBITOR'S account. In the event that a THIRD PARTY orders on behalf of the EXHIBITOR and the named THIRD PARTY does not discharge payment of the invoice prior to the last day of the show, charges will revert back to the EXHIBITOR. All invoices are due and payable upon receipt, by either party.

ELECTRICAL

Claims will not be considered, or adjustments made unless filed in writing, by Exhibitor, prior to the close of the event. Freeman is not responsible for any damage or loss caused by the loss of power beyond its control and Exhibitor agrees to hold Freeman, its officers, directors, employees and agents harmless from such power loss. IN NO EVENT SHALL FREEMAN BE LIABLE FOR ANY INDIRECT OR CONSEQUENTIAL DAMAGES (INCLUDING WITHOUT LIMITATION LOST PROFITS) EVEN IF ADVISED OF THE POSSIBILITY OF SUCH DAMAGES, WHETHER UNDER THEORY OF CONTRACT, TORT (INCLUDING NEGLIGENCE), PRODUCTS LIABILITY OR OTHERWISE. Exhibitor shall indemnify and hold harmless Freeman, its officers, directors, employees, and agents from and against any and all claims, liabilities, damages, fines, penalties or costs of whatsoever nature (including reasonable attorneys' fees) arising out of or in any way connected with Exhibitor's actions or omissions under this Agreement.

LABOR UNDER THE SUPERVISION OF EXHIBITOR RESPONSIBILITIES

EXHIBITOR shall be responsible for the performance of labor provided under this option. It is the responsibility of EXHIBITOR to supervise labor secured through FREEMAN in a reasonable manner as to prevent bodily injury and/or property damage and also to direct them to work in a manner that is in compliance with FREEMAN'S Safe Work Rules and/or Federal, State, County and Local ordinances, rules and/or regulations, including but not limited to Show or Facility Management rules and/or regulations. It is the responsibility of EXHIBITOR to check in with the Service Desk to pick up labor, and to return to the Service Desk to release labor when the work is completed.

INDEMNIFICATION

EXHIBITOR agrees to indemnify, hold harmless, and defend FREEMAN from and against any and all demands, claims, causes of action, fines, penalties, damages, liabilities, judgments, and expenses (including but not limited to reasonable attorneys' fees and investigation costs) for bodily injury, including any injury to FREEMAN employees, and/or property damage arising out of work performed by labor provided by FREEMAN but supervised by EXHIBITOR. Further, the EXHIBITOR'S indemnification of FREEMAN includes any and all violations of Federal, State, County or Local ordinances, "Show Regulations and/or Rules" as published and/or set forth by Facility or Show Management, and/or directing labor provided by FREEMAN to work in a manner that violates any of the above rules, regulations, and/or ordinances.

IMPORTANT

PLEASE REFER TO FREEMAN'S "MATERIAL HANDLING TERMS & CONDITIONS" AS IT RELATES TO MATERIAL HANDLING SERVICES AND TO THE "SERVICE REQUEST & SHIPPING INSTRUCTIONS CONTRACT" AS IT RELATES TO TRANSPORTATION SERVICES. CONTRACT TERMS DEPEND ON THE NATURE OF SERVICES SECURED BY EXHIBITOR THROUGH FREEMAN. TERMS & CONDITIONS MAY VARY FOR EACH TYPE OF SERVICE ORDERED THROUGH FREEMAN.

MATERIAL HANDLING

YOU ARE ENTERING A BINDING CONTRACT WHICH LIMITS YOUR POSSIBLE RECOVERY IN CASE OF LOSS OR DAMAGE. Acceptance of said terms and conditions will be construed when any of the following conditions are met: This Material Handling Agreement (MHA) is signed; Exhibitor's materials are delivered to Freeman's warehouse or to an event site for which Freeman is the Official Show Contractor; or an order for labor and/or rental equipment is placed by Exhibitor with Freeman. Please be aware that disposal of exhibit properties is not included as part of your material handling charges. Please contact freeman for your quoted rates and rules applicable to disposal of your exhibit properties.

1. DEFINITIONS. For purposes of this Contract, Freeman means Freeman Expositions, Inc., and its employees, directors, officers, agents, assigns, affiliated companies, and related entities. In no event shall Freeman be deemed to be the Ultimate Consignee for shipping and custom purposes. The term "Exhibitor" means the Exhibitor, its employees, agents, and representatives.

2. PACKAGING/CRATES AND STORAGE. Freeman shall not be responsible for damage to loose or uncrated materials, pad wrapped or shrink-wrapped materials, glass breakage, concealed damage, carpets in bags or poly, or improperly packed or labeled materials. Freeman shall not be responsible for crates and packaging which are unsuitable for handling, in poor condition, or have prior damage. Crates and packaging should be of a design to adequately protect contents for handling by forklift and similar means. Freeman does not accept any crates or packaging containing hazardous materials. Goods requiring cold storage and those in accessible storage are stored at Exhibitor's own risk. **FREEMAN ASSUMES NO RESPONSIBILITY OR LIABILITY FOR LOSS OR DAMAGE TO GOODS IN COLD STORAGE OR ACCESSIBLE STORAGE.**

3. EMPTY CONTAINERS. Empty container labels will be available at the show site service desk. Affixing labels to the containers is the sole responsibility of Exhibitor or its representative. All previous labels must be removed or obliterated. Freeman assumes no responsibility for: error in the above procedures; removal of containers with old empty labels and without Freeman labels; or improper information on empty labels. **FREEMAN WILL NOT BE LIABLE FOR LOSS OR DAMAGE TO CRATES AND CONTAINERS OR THEIR CONTENTS WHILE SAME ARE IN EMPTY CONTAINER STORAGE.**

4. INBOUND/OUTBOUND SHIPMENTS. There may be a lapse of time between the delivery of shipment(s) to the booth and the arrival of Exhibitor, or a lapse of time between the completion of packing and the actual pickup of materials from the booths for loading onto a carrier and during such times, Exhibitor materials will be left unattended. **FREEMAN IS NOT RESPONSIBLE OR LIABLE FOR ANY LOSS, DAMAGE, THEFT, OR DISAPPEARANCE OF EXHIBITOR'S MATERIALS AFTER THEY HAVE BEEN DELIVERED TO EXHIBITOR'S BOOTH AT SHOW SITE OR BEFORE THEY HAVE BEEN PICKED UP FOR RELOADING AT THE CONCLUSION OF THE EVENT.** Freeman recommends the securing of security services from Facility or Show Management. All MHA's submitted to Freeman by Exhibitor will be checked at the time of pickup from the booth and corrections will be made where discrepancies exist between the quantities of items on any form submitted to Freeman and the actual count of such items in the booth at the time of pickup. Freeman is not responsible for any wait time or other charges including business center charges arising from delivery or pickup of Exhibitor's materials.

5. DELIVERY TO THE CARRIER FOR RELOADING. Freeman assumes no responsibility for loss, damage, theft, or disappearance of Exhibitor's materials after same have been delivered to Exhibitor's appointed carrier, shipper, or agent for transportation after the conclusion of the show. Freeman loads the materials onto the carrier under directions from the carrier or driver of that carrier. Any loading onto the carrier will be understood to be under the exclusive supervision and control of the carrier or driver of that carrier. **FREEMAN ASSUMES NO RESPONSIBILITY FOR LOSS, DAMAGE, THEFT OR DISAPPEARANCE OF EXHIBITOR'S MATERIALS THAT ARISES OUT OF IMPROPERLY LOADED OR LABELED MATERIALS.**

6. DESIGNATED CARRIERS. Freeman shall have the authority to change the Exhibitor designated carrier if that carrier does not pick up the shipment(s) at the appointed time. Where no disposition is made by Exhibitor, materials may be taken to a warehouse to await Exhibitor's shipping instructions and Exhibitor agrees to be responsible for charges relating to such rerouting and handling. **IN NO EVENT SHALL FREEMAN BE RESPONSIBLE FOR ANY LOSS RESULTING FROM SUCH REROUTING DESIGNATION.**

7. FORCE MAJEURE. Freeman's performance hereunder is subject to, and Freeman shall not be responsible for loss, delay, or damage due to, strike, work stoppages, natural elements, vandalism, Act of God, civil disturbances, power failures, explosions, acts of terrorism or war, or for any other cause beyond Freeman's reasonable control, nor for ordinary wear and tear in the handling of Exhibitor's materials.

8. CLAIM(S) FOR LOSS. Exhibitor agrees that any and all claims for loss or damage must be submitted to Freeman immediately at the show site and in any case not later than **thirty (30) business days** after the date when Exhibitor's materials are delivered to the carrier for transportation from show site or from Freeman's warehouse. All claims reported after thirty (30) days will be rejected. In no event shall a suit or action be brought against Freeman **more than one (1) year** after the date of loss or damage occurred.

a. PAYMENT FOR SERVICES MAY NOT BE WITHHELD. In the event of any dispute between the Exhibitor and Freeman relative to any loss, damage, or claim, Exhibitor shall not be entitled to and shall not withhold payment due Freeman for its services as an offset against the amount of any alleged loss or damage. Any claims against Freeman shall be considered a separate transaction and shall be resolved on their own merits.

b. MAXIMUM RECOVERY. If found liable for any loss, Freeman's sole and exclusive maximum liability for loss or damage to Exhibitors materials and Exhibitor's sole and exclusive remedy is limited to \$50 (USD) per pound per article with a maximum liability of \$100.00 (USD) per item, or \$1,500.00 (USD) per shipment whichever is a less. For unmarked, unlabeled and improperly packaged television monitors, the maximum liability is the lesser of \$3.00 (USD) per pound or the actual invoice price. All shipment weights are subject to correction and final charges determined by the actual or re-weighed weight of the shipment.

c. LIMITATION OF LIABILITY. IN NO EVENT SHALL FREEMAN BE LIABLE TO THE EXHIBITOR OR TO ANY OTHER PARTY FOR SPECIAL, COLLATERAL, EXEMPLARY, INDIRECT, INCIDENTAL, OR CONSEQUENTIAL DAMAGES, WHETHER SUCH DAMAGES OCCUR EITHER PRIOR OR SUBSEQUENT TO, OR ARE ALLEGED AS A RESULT OF, TORTIOUS CONDUCT, FAILURE OF THE EQUIPMENT OR SERVICES OF FREEMAN OR BREACH OF ANY OF THE PROVISIONS OF THIS CONTRACT, REGARDLESS OF THE FORM OF ACTION, WHETHER IN CONTRACT OR IN TORT, INCLUDING STRICT LIABILITY AND NEGLIGENCE, EVEN IF FREEMAN HAS BEEN ADVISED OR HAS NOTICE OF THE POSSIBILITY OF SUCH DAMAGES. SUCH EXCLUDED DAMAGES INCLUDE BUT ARE NOT LIMITED TO LOST PROFITS, LOSS OF USE, AND INTERRUPTION OF BUSINESS OR OTHER CONSEQUENTIAL OR INDIRECT ECONOMIC LOSSES.

9. DECLARED VALUE. Declarations of Declared Value are between the Exhibitor and the selected Carrier ONLY, and are in no way an extension of Freeman's maximum liability stated herein. Freeman will use commercially reasonable efforts to transmit the Declared Value instructions to the selected Carrier; however, FREEMAN WILL NOT BE LIABLE FOR ANY CLAIM ARISING FROM THE TRANSMITTAL OF, OR FAILURE TO TRANSMIT, DECLARED VALUE INSTRUCTIONS TO THE CARRIER NOR FOR FAILURE OF THE CARRIER TO UPHOLD THE DECLARED VALUE OR ANY OTHER TERM OF CARRIAGE.

10. JURISDICTION / VENUE. THIS CONTRACT SHALL BE CONSTRUED UNDER THE LAWS OF THE STATE OF TEXAS WITHOUT GIVING EFFECT TO ITS CONFLICT OF LAWS RULES. EXCLUSIVE VENUE FOR ALL DISPUTES ARISING OUT OF OR RELATING TO THIS CONTRACT SHALL RESIDE IN A COURT OF COMPETENT JURISDICTION IN DALLAS COUNTY, TEXAS.

11. INDEMNIFICATION. Exhibitor agrees to indemnify and forever hold harmless Freeman from and against any and all demands, claims, causes of action, fines, penalties, damages (including consequential), liabilities, judgments, and expenses (including but not limited to reasonable attorneys' fees and investigation costs) arising out or contributed to by Exhibitor's negligent supervision of any labor secured through Freeman; Exhibitor's negligence, willful misconduct, or deliberate act, or the negligence, willful misconduct, or deliberate act of Exhibitor's employees, agents, representatives, customers, invitees and/or any Exhibitor Appointed Contractors (EAC) at the show or event to which this Contract relates, including but not limited to Exhibitor's violation of Federal, State, County or Local ordinance and/or Exhibitor's violation of Show Regulations and/or Rules as published and set forth by Facility and/or Show Management.

12. LIEN. Exhibitor grants Freeman a security interest in and a lien on all of Exhibitor's materials that is from time to time in the possession of Freeman and all the proceeds thereof, including without limitation insurance proceeds (the "Collateral"), to secure the prompt and full payment and performance of all Exhibitor's indebtedness for monies paid, by Freeman on its behalf, services performed, materials and/or labor from time to time provided by Freeman to or for the benefit of Exhibitor ("Obligations"). Freeman shall have all the rights and remedies of a secured party under the Uniform Commercial Code, as may be amended from time to time ("UCC"), and any notice that Freeman is required to give under the UCC of a time and place of a public sale or the time after which any private sale or other intended disposition of any Collateral is to be made shall be deemed to constitute reasonable notice if such notice is mailed by registered or certified mail at least five (5) days prior to such action. Freeman may hold and not deliver any of the Collateral to Exhibitor for so long as there are any Obligations that remain unpaid or unsatisfied.

13. WAIVER & RELEASE. Exhibitor, as a material part of the consideration to Freeman for material handling services, waives and releases all claims against Freeman with respect to all matters for which Freeman has disclaimed liability pursuant to the provisions of this Contract.

14. DRIVER LIABILITY WAIVER. IN CONSIDERATION OF FREEMAN PERMITTING ENTRANCE TO THE PREMISES, YOU, YOUR EMPLOYER, THE OWNER OF THE TRUCK AND/OR EQUIPMENT THAT YOU ARE OPERATING (TRUCKOWNER) AND YOU AS AGENT OF YOUR EMPLOYER AND THE TRUCKOWNER, HEREBY ASSUME ALL RISK OF INJURY OR HARM TO YOURSELF AND OTHERS AND DAMAGE TO YOUR PROPERTY AND PROPERTY BELONGING TO YOUR EMPLOYER OR OTHERS ARISING FROM YOUR ACTIVITIES WHILE BEING PERMITTED TO ENTER THE PREMISES. YOU AGREE TO ENTER AT YOUR OWN RISK. YOU HAVE FULL KNOWLEDGE OF ANY RISK INVOLVED IN THIS ACTIVITY. YOU RECOGNIZE THE HAZARDS AND ARE AWARE OF ALL THE RULES FOR SAFE OPERATION. YOUR EMPLOYER, THE TRUCKOWNER, AND YOU AGREE TO INDEMNIFY AND HOLD HARMLESS FREEMAN, ITS EMPLOYEES, OFFICERS, DIRECTORS, AGENTS, ASSIGNS, AFFILIATED COMPANIES AND RELATED ENTITIES, AGAINST ANY AND ALL LIABILITY, ACTIONS, CLAIMS, AND DAMAGES OF ANY KIND WHATSOEVER ARISING FROM YOUR ACTIVITIES WHILE BEING PERMITTED TO ENTER THE PREMISE.

Freeman

TRANSPORTATION COMPLETE



Freeman's all-inclusive shipping and material handling package means transporting your exhibit materials has never been simpler or as affordable.

Double the convenience... zero surprises.

Package includes:

- Round trip standard ground transportation AND material handling services
- No additional fees, no surprises
- Pick-up and transportation from point of origin to either advance warehouse or show site – your choice.
- Pre-printed shipping labels & outbound paperwork

Benefits:

- Turnkey pricing ensures precise budgeting
- No additional handling, pick-up or delivery fees
- No additional fuel surcharges or overtime surcharges
- No carrier waiting time fees
- Experienced on-site transportation reps from move-in through move-out
- All charges on your Freeman invoice
- LTL (less than truck load) shipping

To take advantage, call 1-800-995-3579 or email exhibit.transportation@freemanco.com for a quote.

*Services apply to destinations anywhere in the Continental U.S.



F R E E M A N
INNOVATION DEDICATED TO YOUR BRAND

EXHIBIT transportation



There are many transportation carriers to choose from, but Freeman has more than 85 years of experience in the events industry. No one understands exhibit transportation better than Freeman. Allow us to make the shipping process easy for you.



Between our cost effective solutions, superior customer service and all inclusive pricing, you will find Freeman Exhibit Transportation to be reputable, reliable and convenient. Our transportation experts have the ability to quickly respond to changes when necessary and are available to assist you with all of your show requirements.



Don't forget about inbound shipping! Complete and send the order form to order your inbound and outbound shipping.

EXHIBIT TRANSPORTATION **services**

As the official service contractor, Freeman partners with you and with decision makers at show site – making it easier for you to transport your exhibit to any location.

Some of the benefits of working with Freeman Exhibit Transportation include:

- Guaranteed all inclusive pricing with no additional fees for pickups and deliveries, including weekend and night service.
- One convenient invoice with all your Freeman show services.
- On site transportation experts are available before, during and after the show.
- Customer service seven days a week, offering complete shipment visibility and expert oversight.

questions?

For more information regarding our services, rates, shipment deadlines, documentation requirements, ordering and the terms and conditions of our service offerings, please visit www.freemanco.com

Continental U.S. Exhibitors: Contact our exhibit transportation experts at 800.995.3579 or via email at exhibit.transportation@freemanco.com

International Exhibitors: Contact our exhibit transportation experts at +1.817.607.5183 or via email at international.freight@freemanco.com

F R E E M A N

F R E E M A N

(800) 995-3579 Toll Free US & Canada
(817) 607-5100 Local & International

COMPLETE THIS FORM ONLY IF YOU ARE SHIPPING YOUR EXHIBIT MATERIALS BY FREEMAN EXHIBIT TRANSPORTATION

NAME OF SHOW: **PFA 57TH ANNUAL SYMPOSIUM AND EXPO / NOVEMBER 04 - 05, 2016**

COMPANY NAME: _____ BOOTH #: _____ BOOTH SIZE: _____ X

CONTACT NAME : _____ PHONE #: _____

E-MAIL ADDRESS : _____

For Assistance, please call applicable number listed above to speak with one of our experts.

For fast, easy ordering, go to www.freemanco.com/store

EXHIBIT TRANSPORTATION

TIPS FOR EASY ORDERING

- Credit card information must be on file prior to pick up, as charges will be included on your show services invoice.
- International Exhibitors remember - Shipments originating from countries other than the U.S. must be cleared through customs. Please call for additional information:
(800) 995-3579 Toll Free US & Canada
(817) 607-5100 Local & International

COMPLETE THE FOLLOWING ITEMS ON THIS FORM:

PICK UP INFORMATION

Requested Pick Up Date: _____

SHIPPER NAME _____

SHIPPER ADDRESS _____

(City) (State) (Zip)

DESTINATION

- I will be shipping to the **WAREHOUSE**

FREEMAN / Exhibiting Company Name / Booth #

PFA 57TH ANNUAL SYMPOSIUM AND EXPO

C/O: FREEMAN

841 JOSEPH E LOWERY BLVD N W

ATLANTA, GA 30318

MUST BE DELIVERED BY OCTOBER 28, 2016

- I will be shipping to **SHOW SITE**

FREEMAN / Exhibiting Company Name / Booth #

PFA 57TH ANNUAL SYMPOSIUM AND EXPO

C/O: FREEMAN

RENAISSANCE ATLANTA WAVERLY HOTEL & CONVEN

2450 GALLERIA PKWY SE

ATLANTA, GA 30339

CANNOT BE DELIVERED BEFORE NOVEMBER 04, 2016

TYPE OF SERVICE

- Next Day Air: Delivery next business day by 5:00 PM
- Second Day Air: Delivery second business day by 5:00 PM
- 3-5 Day Service: Delivery within 3 - 5 business days
- Declared Value \$ _____

Air Transportation charges are billed by Dimensional or Actual Weight, whichever is greater.

- Standard Ground: Dependent on distance
- Expedited Ground: Tailored to specific requirements
- Specialized: Pad wrapped, uncrated, truck load

SHIPPING INFORMATION

Items to be shipped

Number of Pieces	Est. Weight
____ Crates (wooden)	_____
____ Cartons (cardboard)	_____
____ Cases/Trunks (fiber) (color _____)	_____
____ Skids/Pallets	_____
____ Carpet (color _____)	_____
____ Other (_____)	_____
____ Total	_____

Size of largest piece: (H) _____ (W) _____ (L) _____

NOTE: Shipments will be weighed and measured prior to delivery.

OUTBOUND SHIPPING

- I would like to schedule outbound Freeman Exhibit Transportation. Please provide me with a Material Handling Agreement at show site for my shipping instructions and signature. So we may print your Outbound Material Handling Agreement and labels, please complete the following information **if different from pick up address:**

Ship to address:

Number of Labels : _____

FAX THIS COMPLETED FORM VIA:

E-mail:

exhibit.transportation@freemanco.com

or

Fax: (469) 621-5810

A TRANSPORTATION SPECIALIST
WILL CALL YOU TO CONFIRM
RECEIPT OF ORDER AND
FINALIZE DETAILS.

SHOW # (435964) _____

FREEMAN exhibit transportation

AIR CARGO

AIR CARGO SERVICE REQUEST AND SHIPPING INSTRUCTIONS CONTRACT

In tendering this shipment, the Shipper and Consignee agree to these TERMS which no agent or employee of the parties may alter. This Air Service Request and Shipping Instruction Contract is NON-NEGOTIABLE and has been prepared by Shipper, or if by Freeman or another on Shipper's behalf, it shall be deemed, conclusively, to have been prepared by the Shipper. The Shipper agrees that this shipment is subject to the TERMS stated herein All TERMS, including but not limited to, all the limitations of liability, shall apply to our agents and their contracting carriers.

1. DEFINITIONS: In this Contract, "Freeman" means Freeman Decorating Services, Inc., and its respective employees, officers, directors, agents, assigns, affiliated companies, and related entities including any contractors appointed by Freeman. The term "Shipper" means the person or business for whom the property is being transported, and includes their respective employees, officers, directors, agents, assigns, affiliated companies, and contractors appointed by the Shipper, excluding only Freeman. "Property" is all objects of any type received from the Shipper for transport by Freeman as described herein. "Consignee" is the party to whom Shipper has designated the goods are to be delivered.

2. FINAL CONTRACT BETWEEN THE PARTIES: In exchange for Shipper's payments and Freeman's services, which the parties have specified in this two-page Contract (including the Air Cargo Service Request and Shipping Instructions), Freeman and Shipper each agree that this Contract shall govern their respective rights and obligations regarding transportation of Shipper's property. This Contract shall take effect when the property first comes into the physical possession of Freeman, and the responsibility of Freeman under same shall end when the property has been placed in the possession of the Consignee or the Consignee's designated agent. If any part or provision of this Contract is found by a court of competent jurisdiction to be void or unenforceable, the remainder of the Contract shall continue in full force and effect.

3. Freeman's RESPONSIBILITIES UNDER THE CONTRACT ARE LIMITED: Freeman is responsible for the satisfactory performance of only those services which it directly provides under this Contract. Freeman shall not be responsible for the performance of individuals of firms who are not under the direct supervision or control of Freeman. Freeman shall not be responsible for events or causes of loss, delay, or damage beyond its reasonable control, including (by way of illustration only, and not as a limitation on the breadth of this clause), strike, lockout, work slowdown or stoppage, power failure, breakdown of plant or machinery, facility failure, vandalism, theft, Act of God, effect of natural elements, riot, civil commotion or disturbance, terrorism, act of war or belligerent parties, and any other cause or causes beyond the reasonable control of Freeman. EXCEPT FOR ELIGIBLE GUARANTEED SERVICE SHIPMENTS, Freeman DOES NOT GUARANTEE DELIVERY BY ANY SPECIFIC TIME OR DATE.

4. PACKAGING AND CRATES: Shipper's property must be well packaged for safe and secure handling, storage and shipment using ordinary care. Each piece must be legibly and durably marked with the name and address, including correct ZIP code of the Shipper and Consignee. When a container is used repeatedly by Shipper, Shipper must remove all old labels, tags, markings, etc., and Shipper must ensure that the container retains adequate strength for transportation. Freeman makes neither representation nor any warranty regarding the acceptability or suitability of any packaging system or procedure that Shipper might use for its property. Freeman shall not be responsible for damage to loose or uncrated materials, padded or shrink-wrapped materials, glass breakage, concealed damage, carpets in bags or poly, or improperly packed or labeled materials. Crates and packaging should be of a design to adequately protect contents for handling by forklift and similar means. General guidance as to acceptable packaging systems and procedures may be found in publications such as the National Motor Freight Classification, published by the National Motor Freight Traffic Association. For shipments of Perishable Commodities, U.S. and Canadian shipments must be packed to travel without spoilage for 72 hours from time of pickup; all international shipments must be packed to travel without spoilage for 24 hours beyond an agreed deadline. Freeman reserves the right to periodically embargo regions of the world due to conditions that may cause damage to perishable commodities. If the integrity of a shipment is in question, Freeman reserves the right to improve packaging at shipper's expense.

5. REFUSED SHIPMENTS: If the Consignee refuses a shipment tendered for delivery or if Freeman is unable to deliver a shipment because of fault or mistake of the Consignor or Consignee, Freeman's liability shall then become that of a warehouseman.

- Freeman shall promptly attempt to provide notice, by telephonic, electronic or written communication as provided on the face of these shipping instructions, if so indicated, to Shipper or the party, if any, designated to receive notice in these instructions.
- Storage charges, based on Freeman's applicable rates, shall start no sooner than the next business day following the attempted notification. Storage may be, at Freeman's option, in any location that provides reasonable protection against loss or damage. Freeman may place the shipment in public storage at the owner's expense and without liability to Freeman.
- If Freeman does not receive disposition instructions within 48 hours of the time of Freeman's attempted first notification, Freeman will attempt to issue a second and final confirmed notification. Such notice shall advise that if Freeman does not receive disposition instructions within 10 days of that notification, Freeman may offer the shipment for sale at a public auction and Freeman has the right to offer the shipment for sale. The amount of sale will be applied to Freeman's invoice for transportation, storage and other lawful charges. Shipper will be responsible for the balance of charges not covered by the sale of the goods. If there is a balance remaining after all charges and expenses are paid, such balance will be paid to the owner of the property sold hereunder, upon claim and proof of ownership.
- Where Freeman has attempted to follow the procedure set forth above and the procedure is not possible, nothing shall be construed to abridge the right of Freeman, at its option, to sell the property under such circumstances and in such manner as may be authorized by law.
- When perishable goods cannot be delivered and disposition is not given within a reasonable time, Freeman may dispose of property to the best advantage. Where Freeman is directed by Consignee or Consignor to unload or deliver property at a particular location where Consignor, Consignee, or the Agent of either is not regularly located, Freeman's liability for the shipment shall terminate after unloading or delivery.

6. LIMITATION ON SHIPPER'S RECOVERABLE DAMAGES: FREEMAN'S LIABILITY FOR DAMAGES ON DOMESTIC SHIPMENTS, INCLUDING BUT NOT LIMITED TO THOSE DAMAGES ARISING FROM OR RELATED TO MISDELIVERY, INCOMPLETE OR OTHERWISE INADEQUATE DELIVERY (INCLUDING BUT NOT LIMITED TO FAILURE TO FOLLOW SHIPPER OR CONSIGNEE INSTRUCTIONS OR FAILURE TO COLLECT OR PROPERLY DELIVER A PAYMENT INSTRUMENT), NONDELIVERY, MISSED PICKUP, AND LOSS OF OR DAMAGE TO CARGO, SHALL BE LIMITED TO THE HIGHER OF \$50.00 (USD) PER SHIPMENT OR \$.50 (USD) PER POUND (\$1.10 (USD) PER KILOGRAM) OF CARGO ADVERSELY AFFECTED THEREBY, PLUS TRANSPORTATION CHARGES APPLICABLE TO THAT PART OF THE SHIPMENT ADVERSELY AFFECTED THEREBY, UNLESS AT TIME OF SHIPMENT THE SHIPPER MAKES A DECLARATION OF VALUE FOR CARRIAGE IN THE SPACE DESIGNATED ON THE SERVICE REQUEST AND SHIPPING INSTRUCTIONS FORM AND PAYS THE APPROPRIATE VALUATION CHARGE. IN NO EVENT SHALL FREEMAN'S LIABILITY EXCEED THE DECLARED VALUE OF THE SHIPMENT OR THE AMOUNT OF LOSS OR DAMAGE ACTUALLY SUSTAINED, WHICHEVER IS LOWER. IF CARRIAGE OF THE SHIPMENT IS SOLELY OR PARTLY BY AIR AND INVOLVES AN ULTIMATE DESTINATION OR A STOP IN A COUNTRY OTHER THAN THE COUNTRY OF DEPARTURE, Freeman's LIABILITY FOR CARGO LOST, DAMAGED OR DELAYED SHALL BE LIMITED TO \$9.07 PER POUND (\$20.00 PER KILOGRAM) FOR CARRIAGE SUBJECT TO THE UNAMENDED WARSAW CONVENTION OR THE WARSAW CONVENTION AS AMENDED BY THE HAGUE PROTOCOL OF 1955, 17 SPECIAL DRAWING RIGHTS PER KILOGRAM FOR CARRIAGE SUBJECT TO THE WARSAW CONVENTION AS AMENDED BY THE MONTREAL PROTOCOL NO. 4 OF 1975, OR \$9.07 PER POUND (\$20.00 PER KILOGRAM) FOR CARRIAGE WHERE THE WARSAW CONVENTION, INCLUDING ITS AMENDMENTS, DOES NOT APPLY FOR ANY REASON, UNLESS A HIGHER DECLARED VALUE IS REQUESTED, AND THE FEES SET FORTH IN THE SERVICE GUIDE FOR SUCH HIGHER DECLARED VALUE ARE PAID. FOR INTERNATIONAL SHIPMENTS, THIS SHIPPING REQUEST AND SHIPPING INSTRUCTION CONTRACT SHALL BE DEEMED AN AIR WAYBILL WITHIN THE MEANING OF THE WARSAW CONVENTION.

Notwithstanding the above limitations, domestic shipments containing the following items of extraordinary value are limited to a maximum declared value of \$500.00 (USD):

- artworks and objects of art, including without limitation original paintings, drawings, etchings, water colors, tapestries and sculpture;
 - clocks, watches, jewelry (including costume jewelry), furs and fur-trimmed clothing;
 - personal effects;
 - and other inherently fragile or unique items, including prototypes, etc.
- Any declared value in excess of the maximums allowed herein is null and void, and the acceptance by Freeman for carriage of any shipment with a declared value in excess of the allowed maximums does not constitute a waiver of these maximums. Shipper understands that even if Shipper is not able to participate or fully participate in a show due to loss of, theft of, or damage to its property, Freeman shall never be liable or responsible for damages identified by the terms (by way of example only and not in limitation of the breadth of this clause) such as the following: consequential damages, loss of use damages, loss of profits damages, business interruption damages, delay damages, special damages, collateral damages, exemplary damages, damages awarded for gross negligence, direct damages, indirect damages, damages for failure of performance, breach of contract damages, fraud damages, or any other sort of damage for tort or breach of contract. This limitation shall bind the parties:
- whenever or wherever the claimed loss or damage may occur;
 - even though the alleged loss or damage is claimed to result from negligence, strict liability, products liability, breach of contract, breach of statute or regulation, or any other legal theory or cause, and;
 - even though Freeman may have been advised or be on notice of the possibility or even the probability of such damages. Freeman makes no warranties, express or implied, and expressly disclaims any and all warranties. Except for Freeman's failure to deliver in accordance with the Guaranteed Service section of the Service Guide, Freeman will not be liable for misdelivery, incomplete or otherwise inadequate delivery (including but not limited to failure to follow Shipper or Consignee instructions or failure to collect or properly deliver a payment instrument), non-delivery, missed pickup, delay on International shipments, loss or damage unless caused by Freeman's sole negligence.

7. SHIPPER'S RESPONSIBILITIES AND INDEMNIFICATION:

- Shipper must pay in full for the services rendered under this Contract at the time the services are requested. The existence of a dispute between Shipper and Freeman relative to any claim or other matter shall have no bearing on this duty of payment. No claim submitted by or on behalf of Shipper will be processed unless Shipper's account is current.
- Shipper understands and acknowledges that Freeman does not accept or transport illegal, dangerous or hazardous materials of any kind or nature. Shipper warrants and ensures that its property is inert, and contains no Hazardous Substances, Hazardous Materials, Chemicals, Gases, Explosives, Radioactive Materials, Biologically hazardous agents, or any other substance, matter or object in any form that could pose a threat to the health or safety of persons, property or the public welfare in general. Such goods may be warehoused at owner's risk and expense or destroyed without compensation.
- Shipper shall defend and indemnify Freeman, its employees, directors, officers, and agents from and against any and all demands, claims, causes of action, fines, penalties, damages (including consequential), liabilities, judgments, and expenses (including but not limited to reasonable attorneys' fees and investigation costs) on account of personal injury, death, or damage to or loss of property or profits arising out of or contributed to by any of the following: Shipper's negligence, willful misconduct, or deliberate act; Shipper's violation of Federal, State, County or Local ordinances; Shipper's violation of Show Regulations and/or Rules as published and set forth by Facility and/or Show Management; and/or Shipper's failure to comply with (b) of this Agreement regarding the inclusion of any dangerous substances in the property placed with Freeman.

8. CLAIMS: Shipper, Consignee, or any other party claiming an interest in the shipment must notify Freeman immediately upon delivery, or in the case of loss or damage which could not have been noted at the time of delivery, within five (5) days of delivery, of any loss or damage to the shipment. Notice of concealed damage must be confirmed in writing. If Carrier schedules an inspection, claimant must hold the shipping container, all packaging material and contents in the same condition as they were in when damage was discovered. Receipt of the shipment by the Consignee or the Consignee's agent without written notice on the delivery receipt and/or delivery manifest will be prima facie evidence that the shipment was delivered in good condition. The amount of the claim may not be deducted from the transportation charges. Notice of loss or damage MUST be reported to Freeman at 800-995-3579. The shipment, its container(s), and packing material must be made available to Freeman for inspection at the delivery location. All shipments are subject to opening for inspection by Freeman; however, Freeman is not obligated to perform such inspection. All claims for loss or damage MUST be made in writing to Freeman within one hundred and twenty (120) calendar days after the date of acceptance of the shipment by Freeman. Please refer to the Service Guide for claim procedures. All claims for service failure must be made within thirty (30) calendar days from the date of shipment and Freeman's sole liability for such claims arising from Guaranteed Service shipments shall be limited to the transportation charges as provided in the Guaranteed Service section of the Service Guide. All claims for overcharge must be made in writing to Freeman within sixty (60) calendar days after the invoice date. No action for loss or damage may be maintained against Freeman unless (a) claimant complies with all requirements of this section and (b) for domestic shipments, if the claimant commences the action within one (1) year of the shipment by Freeman unless otherwise required by International, Federal or State Law. If the claim is for loss or damage involving International shipments, claimant must commence the action within two (2) years from the date of acceptance of the shipment by Freeman unless otherwise required by International, Federal or State Law. For purposes of this section, no action shall be deemed to have commenced until receipt by Freeman of service of process of the action on Freeman. Claims for loss or damage must be delivered to the following address: Sedgwick, PO Box 14151, Lexington, KY 40512-4151.

9. CHOICE OF FORUM: THIS CONTRACT SHALL BE CONSTRUED UNDER THE LAWS OF THE UNITED STATES (INCLUDING ADOPTED INTERNATIONAL CONVENTIONS) AND THE STATE OF TEXAS WITHOUT GIVING EFFECT TO THE STATE'S CONFLICT OF LAWS RULES. FREEMAN AND SHIPPER AGREE THAT ANY CLAIM OR DISPUTE OF ANY SORT ARISING OUT OF OR IN ANY WAY RELATED TO THIS CONTRACT, ITS PERFORMANCE OR NONPERFORMANCE, OR DAMAGES ALLEGEDLY RESULTING FROM SAME WILL BE ARBITRATED IN THE CITY OF DALLAS, TEXAS, AND THE RULES OF THE AMERICAN ARBITRATION ASSOCIATION WILL APPLY. IF BINDING ARBITRATION IS UNAVAILABLE TO RESOLVE ANY CONTROVERSY AND IT IS NECESSARY TO LITIGATE THE DISPUTE, THE DISPUTE SHALL BE LITIGATED IN A COURT OF COMPETENT JURISDICTION IN DALLAS COUNTY, TEXAS.

10. MISCELLANEOUS: Shipper warrants the accuracy of the weight and dimension data furnished in this Contract. Shipper understands that once its property is shipped by Freeman pursuant to the instructions contained in this Contract, Shipper has no right to control the shipment; stop the shipment in transit, or divert or reschedule same, and that Shipper will have no control over the property until it is delivered pursuant to the instructions in this Contract. Shipper agrees that this Contract may be provided to any third party, including common or contract carriers of cargo by air, water, rail, or road, for the purpose of confirming the right of Freeman to control the handling of the property and all matters related to payment for the shipment.

MOTOR CARGO

MOTOR CARGO SERVICE REQUEST AND SHIPPING INSTRUCTIONS CONTRACT

This Contract establishes your legal obligations with regard to the property described herein being shipped with Freeman Transportation. It specifically limits your rights and possible recovery if your property is lost or damaged. You must accept all terms and conditions of this Contract. You confirm that you have read and agree with all the terms and conditions of this Contract by receipt without contest. This Contract may not be waived or varied, except in writing, and then only by an authorized representative of Freeman.

1. DEFINITIONS. In this Contract, "Freeman" means Freeman Expositions, Inc., and its respective employees, officers, directors, agents, assigns, affiliated companies, and related entities including any contractors appointed by Freeman. The term "Shipper" means the person or business for whom the property is being transported, and includes their respective employees, officers, directors, agents, assigns, affiliated companies, and contractors appointed by the Shipper, excluding only Freeman. "Property" is all objects of any type received from the Shipper for transport by Freeman as described herein. "Consignee" is the party to whom Shipper has designated the goods are to be delivered.

2. FINAL CONTRACT BETWEEN THE PARTIES. In exchange for Shipper's payments and Freeman's services, which the parties have specified in this Contract, Freeman and Shipper each agree that this Contract shall govern their respective rights and obligations regarding transportation of Shipper's property. This Contract shall take effect when the property first comes into the physical possession of Freeman for inbound shipments and after loading on the applicable carrier for outbound shipments, and the responsibility of Freeman under same shall end when the property has been placed in the possession of the Consignee or the Consignee's designated agent. If any part or provision of this Contract is found by a court of competent jurisdiction to be void or unenforceable, the remainder of the Contract shall continue in full force and effect.

3. FREEMAN'S RESPONSIBILITIES UNDER THE CONTRACT ARE LIMITED. Freeman shall not be responsible for the performance of individuals or firms who are not under the direct supervision or control of Freeman. Freeman shall not be responsible for events or causes of loss, delay, or damage beyond its reasonable control, including (by way of illustration only, and not as a limitation on the breadth of this clause), strike, lockout, work slowdown or stoppage, power failure, breakdown of plant or machinery, facility failure, vandalism, theft, Act of God, effect of natural elements, riot, civil commotion or disturbance, terrorism, act of war or belligerent parties, and any other cause or causes beyond the reasonable control of Freeman. Freeman shall not be liable for delay caused by highway obstructions, or faulty or impassable highways, or lack of capacity of any highway, bridge, or ferry, or caused by breakdown or mechanical defects of vehicles or equipment, or from any cause other than the negligence of Freeman. Freeman shall not be bound to transport by any particular schedule, means, vehicle or otherwise, other than with reasonable dispatch.

4. PACKAGING AND CRATES. Shipper's property must be well packaged for safe and secure handling, storage and shipment using ordinary care. Freeman makes neither representation nor any warranty regarding the acceptability or suitability of any packaging system or procedure that Shipper might use for its property. Freeman shall not be responsible for damage to loose or uncrated materials, padwrapped or shrink-wrapped materials, glass breakage, concealed damage, carpets in bags or poly, or improperly packed or labeled materials. Crates and packaging should be of a design to adequately protect contents for handling by forklift and similar means. General guidance as to acceptable packaging systems and procedures may be found in publications such as the National Motor Freight Classification, published by the National Motor Freight Traffic Association. If the integrity of a shipment is in question, Freeman reserves the right to improve packaging at shipper's expense.

5. PERISHABLE GOODS. Goods of a perishable nature are carried in dry trailers without environmental or atmospheric control or other special services unless Shipper states on the face of the "Service Request and Shipping Instructions" that the goods are to be carried in a refrigerated, heated, specially ventilated or otherwise specially equipped trailer. This carriage may be subject to additional charges. Shipper is responsible for bringing the goods to the proper temperature before loading the goods into the trailer, for the proper storage of the goods within the trailer, and for setting the temperature (including maintenance and repair), during all times after the trailer is spotted by Freeman and before the trailer is received by Freeman. Freeman is not responsible for product deterioration caused by inherent vice, defects in the merchandise or transit times in excess of product shelf life. Refrigerated, heated, specially ventilated or otherwise specially equipped trailers are not equipped to change the temperature of goods (they are equipped only to maintain temperature). Shipper will give written notice of requested temperature setting of the thermostatic controls before receipt of the goods by Freeman. When a loaded trailer is received, Freeman will verify that the thermostatic controls are set to maintain trailer temperature as requested. Freeman is unable to determine whether the goods were at the proper temperature when they were loaded into the trailer or when the trailer is delivered to Freeman. Air temperature at the unit sensor will be maintained within a proper range of plus or minus 5 degrees Fahrenheit of the temperature requested by Shipper on the face of the "Service Request and Shipping Instructions" if the goods were at that temperature when loaded into the container and if the temperature controls were properly set when the container was loaded.

6. REFUSED SHIPMENTS. If the Consignee refuses a shipment tendered for delivery or if Freeman is unable to deliver a shipment because of fault or mistake of Freeman, Freeman's liability shall then become that of a warehouseman.

(a) Freeman shall promptly attempt to provide notice, by telephonic, electronic or written communication as provided on the face of these shipping instructions, if so indicated, to Shipper or the party, if any, designated in these instructions to receive notice.

(b) Storage charges, if applicable, shall start no sooner than the next business day following the attempted notification. Storage may be, at Freeman's option, in any location that provides reasonable protection against loss or damage. Freeman may place the shipment in public storage at the owner's expense and without liability to Freeman.

(c) If Freeman does not receive disposition instructions within 48 hours of the time of Freeman's attempted first notification, Freeman will attempt to issue a second and final confirmed notification. Such notice shall advise that if Freeman does not receive disposition instructions within 10 days of that notification, Freeman may offer the shipment for sale at a public auction and Freeman has the right to offer the shipment for sale. The amount of sale will be applied to Freeman's invoice for transportation, storage and other lawful charges. Shipper will be responsible for the balance of charges not covered by the sale of the goods. If there is a balance remaining after all charges and expenses are paid, such balance will be paid to the owner of the property sold hereunder, upon claim and proof of ownership.

(d) Where Freeman has attempted to follow the procedure set forth above and the procedure is not possible, nothing shall be construed to abridge the right of Freeman, at its option, to sell the property under such circumstances and in such manner as may be authorized by law.

(e) When perishable goods cannot be delivered and disposition is not given within a reasonable time, Freeman may dispose of property to the best advantage. When Freeman is directed by Consignee or Consignor to unload or deliver property at a particular location where Consignor, Consignee, or the Agent of either is not regularly located, Freeman's liability for the shipment shall terminate after unloading or delivery.

7. INSURANCE. Freeman IS NOT AN INSURER. Shipper is responsible for obtaining insurance for its property. Freeman provides no insurance for Shipper or its property.

8. LIMITATION ON SHIPPER'S RECOVERABLE DAMAGES. Shipper understands that even if shipper's property is lost, stolen, or damaged, Freeman does not pay replacement or restoration cost of any property. **FREEMAN'S MAXIMUM LIABILITY SHALL BE THE AMOUNT OF PROVEN ACTUAL VALUE NOT EXCEEDING THE LOWER OF FAIR MARKET VALUE.**

(THE "FAIR MARKET VALUE" EQUALS THE AS IS WHERE IS PRICE FOR THE PROPERTY AT THE LOCATION OF THE SHOW TO WHICH PRICE A WILLING BUYER AND A WILLING SELLER WOULD AGREE IN AN ORDINARY COURSE OF BUSINESS, ARM'S LENGTH SALE, OR \$5.00 (USD) PER POUND OF CARGO LOST OR DAMAGED UNLESS AT THE TIME OF SHIPMENT SHIPPER MAKES A DECLARATION OF VALUE FOR CARRIAGE IN THE SPACE DESIGNATED ON THE SHIPPING INSTRUCTIONS AND PAYS THE APPROPRIATE VALUATION CHARGE. Even if Shipper has made a declaration of value, liability shall never exceed the depreciated original invoice value or the fair market value of the property, whichever is less. The value per pound for applying declared valuation charges shall be determined by dividing Shipper's declared value for carriage by the actual weight of the shipment. In all cases not prohibited by law, where a lower value than the actual value of the said property has been stated in writing by Shipper or has been agreed upon in writing as the released value of the property upon which the rate is based, such lower value plus freight charges, if paid, shall be the maximum recoverable amount for loss or damage. **Notwithstanding the above limitations, all shipments containing the following items of extraordinary value are limited to a maximum declared value of \$500.00 (USD):** (a) Artworks and objects of art, including without limitation, original paintings, drawings, etchings, watercolors, tapestries and sculptures or prototypes; (b) Clocks, jewelry, including costume jewelry, furs, and fur-trimmed clothing; (c) Personal effects, including without limitation, papers and documents; or (d) Coin money, currency, gift certificates, debit cards, credit cards, and any other items of extraordinary value. (e) For unmarked, unlabeled and improperly packaged television monitors, the maximum liability is the lesser of \$3.00 (USD) per pound or the actual invoice price.

Any declared value in excess of the maximums allowed herein is null and void, and the acceptance by Freeman for carriage of any shipment with a declared value in excess of the allowed maximums does not constitute a waiver of these maximums. In any event, (excluding small package program shipments) **Freeman's MAXIMUM LIABILITY WILL NEVER BE MORE THAN \$100,000 PER SHIPMENT.** Shipper understands that even if Shipper is not able to participate or fully participate in a Show due to loss of, theft of, or damage to their property, Freeman shall not be liable or responsible for damages identified by the terms (by way of example only and not in limitation of the breadth of this clause) such as the following: consequential damages, loss of use damages, loss of profits damages, business interruption damages, delay damages, special damages, collateral damages, exemplary damages, damages awarded for gross negligence, direct damages, indirect damages, or damages for failure of performance, breach of contract damages, fraud damages, or any other sort of damage for tort or breach of contract. This limitation shall bind the parties: **(a) WHENEVER OR WHEREVER THE CLAIMED LOSS OR DAMAGE MAY OCCUR; (b) EVEN THOUGH THE ALLEGED LOSS OR DAMAGE IS CLAIMED TO RESULT FROM NEGLIGENCE, STRICT LIABILITY, PRODUCTS LIABILITY, BREACH OF CONTRACT, BREACH OF STATUTE OR REGULATION, OR ANY OTHER LEGAL THEORY OR CAUSE, AND; (c) EVEN THOUGH FREEMAN MAY HAVE BEEN ADVISED OR BE ON NOTICE OF THE POSSIBILITY OR EVEN THE PROBABILITY OF SUCH DAMAGES.**

9. SHIPPER'S RESPONSIBILITIES AND INDEMNIFICATION:

(a) Shipper must pay in full for the services rendered under this Agreement at the time the services are requested. The existence of a dispute between Shipper and Freeman relative to any claim or other matter shall have no bearing on this duty of payment. No claim may be submitted by or on behalf of Shipper to Freeman unless Shipper's account is current.

(b) Shipper understands and acknowledges that Freeman does not accept or transport illegal or hazardous materials of any kind or nature. Shipper warrants and will ensure that its property is inert, and contains no Hazardous Substances, Hazardous Materials, Chemicals, Gasses, Explosives, Radioactive Materials, Biologically hazardous agents, or any other substance, matter or object in any form that could pose a threat to the health or safety of Freeman persons, property, or the public welfare in general. Such goods may be warehoused at owner's risk and expense or destroyed without compensation.

(c) Shipper shall defend and indemnify Freeman, its employees, directors, officers, and agents from and against any and all demands, claims, causes of action, fines, penalties, damages (including consequential), liabilities, judgments, and expenses (including but not limited to reasonable attorneys' fees and investigation costs) on account of personal injury, death, or damage to or loss of property or profits arising out of or contributed to by any of the following: Shipper's negligence, willful misconduct, or deliberate act; Shipper's violation of Federal, State, County or Local ordinances; Shipper's violation of Show Regulations and/or Rules as published and set forth by Facility and/or Show Management; and/or Shipper's failure to comply with subsection (b) of this section regarding the inclusion of any dangerous substances in the property placed with Freeman.

10. CLAIMS. Claims must be filed in writing within nine (9) months after the date of delivery of the property (or in the case of export traffic, within nine (9) months after delivery at the port of export), except that claims for failure to make delivery must be filed within nine (9) months after a reasonable time for delivery has elapsed. Suits for loss, damage, or delay shall be instituted against Freeman no later than two (2) years and one (1) day from the day when written notice is given by Freeman to the claimant that Freeman has disallowed the claim or any part or parts of the claim specified in the notice. Shipper shall deliver notice of claim for loss or damage by hand, U.S. mail, courier, facsimile, or electronic means to Sedgwick, PO Box 14151, Lexington, KY 40512-4151 as soon as loss or damage is discovered. The notice of claim shall invite a prompt joint survey of the damage, at a time and place to be agreed between the parties, and such survey shall go forward promptly. However, if in any case the property is received by the Consignee or the Consignee's agent without notice of loss or damage to property being served on Freeman within 5 calendar days of the receipt of the property, it is agreed between Freeman and Shipper that in that instance the presumption shall arise that the property was delivered in proper quantity and in good condition. Notice of concealed damage must be confirmed in writing. If Carrier schedules an inspection, claimant must hold the shipping container, all packaging material and contents in the same condition as they were in when damage was discovered. Claims filed more than nine (9) months following the date on which the property was delivered or should have been delivered are agreed to be forever time barred.

11. CHOICE OF FORUM / ARBITRATION. THIS CONTRACT SHALL BE CONSTRUED UNDER THE LAWS OF THE STATE OF TEXAS WITHOUT GIVING EFFECT TO ITS CONFLICT OF LAWS RULES. EXCLUSIVE VENUE FOR ALL DISPUTES ARISING OUT OF CONTRACT, TORT, COMMON LAW OR RELATING TO THE ENFORCEMENT OR INTERPRETATION OF THIS CONTRACT SHALL RESIDE IN A COURT OF COMPETENT JURISDICTION IN DALLAS COUNTY, TEXAS. Notwithstanding anything herein to the contrary, any controversy or claim arising out of or relating to this Agreement, or the breach thereof, shall be exclusively settled by arbitration administered by the American Arbitration Association in accordance with its Commercial Arbitration Rules and judgment on the award rendered by the arbitrator(s) may be entered by any court having jurisdiction thereof.

12. MISCELLANEOUS. (a) Shipper warrants the accuracy of the weight and dimension data furnished in this Contract; (b) Shipper understands that once its property is shipped by Freeman pursuant to the instructions contained in this Contract, Shipper has no right to control the shipment, stop the shipment in transit, or divert or reschedule same. (c) Shipper agrees that this Contract may be provided to any third party, including common or contract carriers of cargo by air, water, rail, or road, for the purpose of confirming the right of Freeman to control the handling of the property and all matters related to payment for the shipment. Shipper agrees that all shipments are subject to correction and final charges determined by the actual or re-weighted weight of the shipment.

13. SMALL PACKAGE PROGRAM. If items shipped via Freeman's Small Packages program are lost, damaged or destroyed while in Freeman's possession, **FREEMAN'S MAXIMUM LIABILITY SHALL BE \$100 per package UNLESS AT THE TIME OF SHIPMENT SHIPPER MAKES A DECLARATION OF VALUE IN THE SPACE DESIGNATED ON THE SHIPPING INSTRUCTIONS AND PAYS THE APPROPRIATE VALUATION CHARGE.** If small packages are received by the Shipper and notice of loss or damage is not received by Freeman within 15 days of the delivery of the property, the parties agree that the presumption shall arise that the property was delivered in proper quantity and in good condition.

WHAT ARE FREIGHT SERVICES?

As the official service contractor, Freeman is the exclusive provider of freight services. Material handling includes unloading your exhibit material, storing up to 30 days in advance at the warehouse address, delivering to the booth, the handling of empty containers to and from storage, and removing of material from the booth for reloading onto outbound carriers. It should not be confused with the cost to transport your exhibit material to and from the convention or event. You have two options for shipping your advance freight — either to the warehouse or directly to show site.

How do I ship to the warehouse?

- We will accept freight beginning 30 days prior to show move-in.
- To check on your freight arrival, call Exhibitor Services at the location listed on Quick Facts.
- To ensure timely arrival of your materials at show site, freight should arrive by the deadline date listed on Quick Facts. Your freight will still be received after the deadline date, but additional charges will be incurred.
- The warehouse will receive shipments Monday through Friday, except holidays. Refer to Quick Facts for warehouse hours. No appointment is necessary.
- The warehouse will accept crates, cartons, skids, trunks/cases and carpets. Loose or pad-wrapped material must be sent directly to show site.
- All shipments must have a bill of lading or delivery slip indicating the number of pieces, type of merchandise and weight.
- Certified weight tickets must accompany all shipments.
- Warehouse freight will be delivered to the booth prior to exhibitor set up.

How do I ship to show site?

- Freight will be accepted only during exhibitor move-in. Please refer to Quick Facts for the specific exhibitor move-in dates and times.
- All shipments must have a bill of lading or delivery slip indicating the number of pieces, type of merchandise and weight.
- Certified weight tickets must accompany all shipments.

What about prepaid or collect shipping charges?

- Collect shipments will be returned to the delivery carrier.
- To ensure that your freight does not arrive collect, mark your bill of lading “prepaid.”
- “Prepaid” designates that the transportation charges will be paid by the exhibitor or a third party.

How should I label my freight?

- The label should contain the exhibiting company name, the booth number and the name of the event.
- The specific shipping address for either the warehouse or show site is located on Quick Facts.

How do I estimate my Material Handling charges?

- Charges will be based on the weight of your shipment. Each shipment received is considered separately. The shipment weight will be rounded to the next 100 pounds. Each 100 pounds is considered one “cwt.” (one hundred weight). All shipments are subject to reweigh.
- On the Order Form, select whether the freight will arrive at the warehouse or be sent directly to show site.
- Next, select the category that best describes your shipment. There are four categories of freight:

Crated: material that is skidded or is in any type of shipping container that can be unloaded at the dock with no additional handling required.

Special Handling: material delivered by the carrier in such a manner that it requires additional handling, such as ground unloading, stacked and constricted space unloading, designated piece unloading, loads mixed with pad-wrapped material, loads failing to maintain shipping integrity, and shipments that require additional time, equipment or labor to unload. Federal Express and UPS are included in this category due to their delivery procedures.

Uncrated: material that is shipped loose or pad-wrapped, and / or unskidded machinery without proper lifting points.

Carpet and/or Pad Only: shipments that consist of loose carpet and/or padding only require additional labor and equipment to unload.

- Add overtime charges for inbound if material is delivered to the booth during the overtime period stated on Quick Facts. This includes both warehouse and show site shipments.

- Add overtime charges for outbound if material is loaded onto the outbound carrier during the overtime period stated on Quick Facts.
- Add the late delivery charge listed on the Order Form if the shipment is accepted at the warehouse or at show site after the deadline date listed on Quick Facts.
- The above services, whether used completely or in part, are offered as a package and the charges will be based on the total inbound weight of the shipment.
- Shipments received without receipts or freight bills, such as UPS and Federal Express, will be delivered to the booth without guarantee of piece count or condition.

What happens to my empty containers during the show?

- Pick up “Empty Labels” at the Service Center. Place a label on each container. Labeled containers will be picked up periodically and stored in non-accessible storage during the show.
- At the close of the show, the empty containers will be returned to the booth in random order. Depending on the size of the show, this process may take several hours.

How do I protect my materials after they are delivered to the show or before they are picked up after the show?

- Consistent with trade show industry practices, there may be a lapse of time between the delivery of your shipment(s) to your booth and your arrival. The same is true for the outbound phase of the show — the time between your departure and the actual pick-up of your materials. During these times, your materials will be left unattended. We recommend that you arrange for a representative to stay with your materials or that you hire security services to safeguard your materials.

How do I ship my materials after the close of the show?

- Each shipment must have a completed Material Handling Agreement in order to ship materials from the show. All pieces must be labeled individually.
- To save time, complete and submit the Outbound Shipping Form in advance, or you may contact the Service Center at show site for your shipping documents. The Material Handling Agreement and labels will be processed and available prior to show closing.
- After materials are packed, labeled, and ready to be shipped, the completed Material Handling Agreement must be turned in at the Service Center.
- Call your designated carrier with pick-up information. Please refer to Quick Facts for specific dates and times. In the event your selected carrier fails to show on final move-out day, your shipment will either be rerouted on Freeman’s carrier choice or delivered back to the warehouse at the exhibitor’s expense.
- For your convenience, show recommended carriers will be on site to handle outbound transportation.

Where do I get a forklift?

- Forklift orders to install or dismantle your booth after materials are delivered may be ordered in advance or at show site. We recommend that you order in advance to avoid additional charges at show site. Refer to the Order Form for available equipment.
- Advance and show site orders for equipment and labor will be dispatched once a company representative signs the labor order at the Service Center.
- Start time is guaranteed only when equipment is requested for the start of the working day.

Do I need insurance?

- Be sure your materials are insured from the time they leave your firm until they are returned after the show. It is suggested that exhibitors arrange all-risk coverage. This can be done by riders to your existing policies.
- All materials handled by Freeman are subject to the enclosed Terms and Conditions.

Other available services (may not be available in all locations)

- Cranes
- Scissor lifts, condors
- Access storage at show site
- Exhibit transportation services (see enclosed brochure)
- Security storage at show site
- Short-term and long-term warehouse storage
- Local pick-up and delivery
- Priority empty return

FREEMAN

841 Joseph E. Lowery Blvd N W
Atlanta, GA 30318
(404) 253-6494 Fax: (469) 621-5610
FreemanAtlantaES@freemanco.com

**INCLUDE THE FREEMAN METHOD OF
PAYMENT FORM WITH YOUR ORDER**

NAME OF SHOW: **PFA 57TH ANNUAL SYMPOSIUM AND EXPO / NOVEMBER 04 - 05, 2016**

COMPANY NAME _____ BOOTH #: _____

CONTACT NAME: _____ PHONE #: _____

E-MAIL ADDRESS _____

For Assistance, please call 404-253-6494 to speak with one of our experts.

Let Freeman OnLine® estimate your material handling charges for you. Log on to www.freemanco.com/store, select your show and click on "Estimate My Material Handling Costs". From Freeman OnLine® you can print extra shipping labels, get tips on how to package your freight and much more.

MATERIAL HANDLING SERVICES

- CRATED:** Material that is skidded or is in any type of shipping container that can be unloaded at the dock with no additional handling required.
- SPECIAL HANDLING:** Material delivered in such a manner that it requires additional handling, such as ground unloading, stacked or constricted space unloading, designated piece unloading, shipment integrity, alternate delivery location, loads mixed with pad wrapped material, no documentation and shipments that require additional time, equipment or labor to unload. **Federal Express, UPS & DHL** are included in this category due to their delivery procedures.
- UNCRADED:** Material that is shipped loose or pad-wrapped, and/or unskidded machinery without proper lifting points.
- CARPET AND/OR PAD ONLY:** Shipments that consist of loose carpet and/or padding only require additional labor and equipment to unload.
- STRAIGHT TIME:** 8:00 A.M. to 5:00 P.M. Monday through Friday
- OVERTIME:** 5:00 P.M. to 8:00 A.M. Monday through Friday, all day Saturday, Sunday, and Holidays
(Overtime will be applied to all freight received at the warehouse and/or show site that must be moved into or out of booth during above listed times.)

Description	Price Per CWT	200 lb. Minimum
RATE CLASSIFICATIONS:		
Warehouse Shipment (200 lb. minimum)		
Crated or Skidded Shipment.....	\$ 79.25	158.50
Special Handling Shipment.....	\$103.25	206.50
Carpet and/or Pad Only Shipment.....	\$ 119.00	238.00
Show Site Shipment (200 lb. minimum)		
Crated or Skidded Shipment.....	\$ 81.00	162.00
Special Handling Shipment.....	\$105.50	211.00
Uncrated or Pad Wrapped Shipment.....	\$121.50	243.00
Carpet and/or Pad Only Shipment.....	\$121.50	243.00
Small Package - Maximum weight is 30 lbs per shipment*		
Per Shipment.....	\$ 40.00	

*A small package shipment is a shipment totaling any number of pieces with a combined weight not to exceed 30 lbs that is received on the same day, from the same shipper and delivered by the same carrier.

ADDITIONAL SURCHARGES:

Shipment Delivered after Deadline Date (in addition to above rates)		
Warehouse Shipment after Deadline.....	\$ 20.00	40.00
Show Site Shipment after Deadline.....	\$ 20.25	40.50
Overtime Charge - Inbound (in addition to above rates)		
Crated or Skidded Shipment.....	\$ 20.25	40.50
Special Handling Shipment.....	\$ 26.50	53.00
Uncrated or Pad Wrapped Shipment.....	\$ 30.50	61.00
Carpet and/or Pad Only Shipment.....	\$ 30.50	61.00
Overtime Charge - Outbound (in addition to above rates)		
Crated or skidded Shipment.....	\$ 20.25	40.50
Special Handling Shipment.....	\$ 26.50	53.00
Uncrated or Pad Wrapped Shipment.....	\$ 30.50	61.00
Carpet and/or Pad Only Shipment.....	\$ 30.50	61.00

Description	Weight	CWT	Price per CWT	Estimated Total Cost (200 lb. Min.)
	÷ 100 =			
Surcharges	÷ 100 =			
			0.00% Tax	N/A
			Total	

SPECIAL HANDLING DEFINITIONS

for frequently asked questions and material handling estimator tools, go to www.freemanco.com/store

Special handling applies to shipments that are loaded by cubic space and/or packed in such a manner as to require additional labor/handling, such as ground unloading, constricted space unloading, designated piece unloading, or stacked shipments. Also included are shipment integrity, alternate delivery locations, mixed shipments, and shipments without individual bills of lading. Shipments loaded in this manner require additional time, labor, or equipment, to unload, sort and deliver.

What is Ground Loading/Unloading?

Vehicles that are not dock height, preventing the use of loading docks, such as U-hauls, flat bed trailers, double drop trailers, company vehicles with trailers that are not dock level, etc.

What is Constricted Space Loading/Unloading?

Trailer loaded "high and tight" shipments that are not easily accessible. Freight is loaded to full capacity of trailer – top to bottom, side to side. One example of this is freight that is loaded down one side of a trailer that must be bypassed to reach targeted freight.

What is Designated Piece Loading/Unloading?

Drivers that require the loading crew to bring multiple pieces of the freight to the rear of the trailer to select the next piece, having to remove freight from the trailer then reload to fit or the trailer must be loaded in a sequence to ensure all items fit.

What are Stacked Shipments?

Shipments loaded in such a manner requiring multiple items to be removed to ground level for delivery to booth. Stacked or "cubed out" shipments, loose items placed on top of crates and/or pallets constitute special handling.

What is Shipment Integrity?

Shipment integrity involves shipments on a carrier that are intermingled, or delivered in such a manner that additional labor is needed to sort through and separate the various shipments on a truck for delivery to our customers.

What is Alternate Delivery Location?

Alternative delivery location refers to shipments that are delivered by a carrier that requires us to deliver some shipments to different levels in the same building, or to other buildings in the same facility.

What are Mixed Shipments?

Mixed shipments are defined as shipments of mixed crated and uncrated goods, where the percentage of uncrated is minimal and does not warrant the full uncrated rate for the shipment, but does require special handling. Freeman defines special handling for mixed loads as having less than 50% of the volume as uncrated.

What does it mean if I have "No Documentation"?

Shipments arrive from a small package carrier (including, among others, Federal Express, UPS & DHL) without an individual Bill of Lading, requiring additional time, labor and equipment to process.

What is the difference between Crated and Uncrated Shipments?

Crated shipments are those that are packed in any type of shipping container that can be unloaded at the dock with no additional handling required. Such containers include crates, fiber cases, cartons, and properly packed skids. An uncrated shipment is material that is shipped loose or pad-wrapped, and/or unskidded without proper lifting points.

What about carpet only shipments?

Shipments that consist of loose carpet and/or padding only require additional labor and equipment to unload.

F R E E M A N

841 Joseph E Lowery Blvd N W
 Atlanta, GA 30318
 (404) 253-6494 Fax: (469) 621-5610
 FreemanAtlantaES@freemanco.com

OUTBOUND MATERIAL HANDLING
 AND SHIPPING LABELS

NAME OF SHOW: **PFA 57TH ANNUAL SYMPOSIUM AND EXPO / NOVEMBER 04 - 05, 2016**

COMPANY NAME: _____ BOOTH #: _____ BOOTH SIZE: _____ X _____

CONTACT NAME : _____ PHONE #: _____

E-MAIL ADDRESS : _____

For Assistance, please call (404) 253-6494 to speak with one of our experts.

For fast, easy ordering, go to www.freemanco.com/store

EVERY OUTBOUND SHIPMENT WILL REQUIRE A MATERIAL HANDLING AGREEMENT AND SHIPPING LABELS. WE WOULD BE HAPPY TO PREPARE THESE FOR YOU AND DELIVER THEM TO YOUR BOOTH PRIOR TO SHOW CLOSE. TO TAKE ADVANTAGE OF THIS SERVICE, PLEASE COMPLETE AND RETURN THIS FORM.

SHIPPING INFORMATION

SHIP TO: COMPANY NAME: _____

DELIVERY ADDRESS: _____

CITY: _____ STATE/ PROVINCE: _____ ZIP/ POSTAL CODE: _____

PHONE#: _____ ATTN: _____

SPECIAL INSTRUCTIONS: _____

BILL TO: Same as Ship to:

COMPANY NAME: _____

DELIVERY ADDRESS: _____

CITY: _____ STATE/ PROVINCE: _____ ZIP/ POSTAL CODE: _____

METHOD OF SHIPMENT

Select a Carrier:

Freeman Exhibit Transportation **Other Carrier**

No need to schedule your outbound shipment. Carrier Name: _____
 Charges will appear on your Freeman invoice. Carrier Phone: _____

Freeman will make arrangements for all Freeman Exhibit Transportation shipments.
 Arrangements for pick-up by other carriers is the responsibility of the exhibitor.

Select a Level of Service:

1 Day: Delivery next business day Standard Ground
 2 Day: Delivery by 5:00 P.M. second business day Specialized: Pad wrapped, uncrated, or truckload
 Deferred: Delivery within 3-5 business days

Select Shipment Options (if applicable)

Have loading dock Lift gate required
 Inside delivery Air ride required
 Pad wrap required Residential
 Do not stack

Select Desired Number of Labels: _____

Once your shipment is packed and ready to be picked up, please return the Material Handling Agreement to the Exhibitor Services Center. Shipments without a Material Handling Agreement turned in will be returned to our warehouse at exhibitor's expense.

F R E E M A N

R U S H

DO NOT DELAY

F R E E M A N

R U S H

DO NOT DELAY

RECEIVING DATE BEGINS: OCTOBER 05, 2016

RECEIVING DATE BEGINS: OCTOBER 05, 2016

DEADLINE DATE IS: OCTOBER 28, 2016

DEADLINE DATE IS: OCTOBER 28, 2016

TO: _____

EXHIBITOR NAME

TO: _____

EXHIBITOR NAME

C/O: FREEMAN
841 JOSEPH E LOWERY BLVD N W

ATLANTA, GA 30318

C/O: FREEMAN
841 JOSEPH E LOWERY BLVD N W

ATLANTA, GA 30318

WAREHOUSE

WAREHOUSE

PFA 57TH ANNUAL SYMPOSIUM AND

PFA 57TH ANNUAL SYMPOSIUM AND

EVENT: _____
EXPO

EVENT: _____
EXPO

BOOTH NO: _____ **NO.** _____ **OF** _____ **PCS**

BOOTH NO: _____ **NO.** _____ **OF** _____ **PCS**

THE ABOVE LABELS ARE PROVIDED FOR YOUR CONVENIENCE.
PLACE ONE ON EACH PIECE SHIPPED TO ENSURE PROPER DELIVERY.
IF MORE LABELS ARE NEEDED, COPIES ARE ACCEPTABLE.

FURNISHING essentials 2

seating

When it comes to basic seating needs, look no further than Freeman. Our well-designed modern chairs, armchairs and stools will serve any exhibitor's show space requirements.



soho bistro table (page 2)

black diamond stool

22"W 18"L 46"H – N71088

diva series

Natural blonde wood and matte chrome finish highlight this sleek Italian design.

diva counter stool

17"W 16"L 36"H – N71092

The intermediate 25" seating height makes this stool ideal for theater or demo areas.

diva chair

18"W 16"L 31"H – N71091

A natural complement to modern exhibit designs.



black diamond side chair

21"W 23"L 32"H – N71089

black diamond armchair

20"W 21"L 33"H – N71090



gray gaslift stool

24"W 20"L 46"H

With Arms – N71048

No Arms – N71047

gray gaslift chair

26"W 20"L 38"H

With Arms – N71046

No Arms – N71045

Telescoping height adjustment; five-caster base rolls with ease.



limerick® stool by Herman Miller*Gray*

18"W 17.75"L 44"H – C210109

limerick® chair by Herman Miller*Gray*

18"W 17.75"L 33"H – C210108



tables

What Freeman always brings to the table is professionalism, and nothing says more about your meeting space and/or show site than your surfaces and tabletops. Choose from modern glass conference tables, traditional cocktail, end tables and much more.

pedestal tables

A range of table-top sizes and materials with pedestals in various heights to fit any space.

soho series

Black-Top Mini	18" Round 18"H	N72066
Black-Top Café	24" Round 30"H	N72069
Black-Top Bistro	24" Round 42"H	N72070
Black-Top Café	36" Round 30"H	N72067
Black-Top Bistro	36" Round 42"H	N72068

**chelsea series**

Butcher Block-Top Café	30" Round 30"H	N72063
	36" Round 30"H	N72064
Butcher Block-Top Bistro	30" Round 42"H	N720163
	36" Round 42"H	N720164



studio series

black end table

17"W 17"L 18"H – C115104

black cocktail table

36"W 20"L 15"H – C115103



display

Some of the most essential elements of your exhibit are the surfaces on which you display your show materials. That’s why we have an appealing variety of displays, from standing cylinders to sleek computer desks to draped tables and counters, to ensure your show space will be both attractive and interactive.

draped or undraped table counters

Colored draping includes white vinyl top and pleated skirt on three sides. Fourth-side draping is available. Undraped tables include white vinyl tops.



	3'	4'	6'	8'
tables (30" height)				
Draped	C130330	C130430	C130630	C130830
Draped on fourth side			C12404630	C12404830
Undraped	C131330	C131430	C131630	C131830
counters (42" height)				
Draped	C130342	C130442	C130642	C130842
Draped on fourth side			C12404642	C12404842
Undraped	C131342	C131442	C131642	C131842

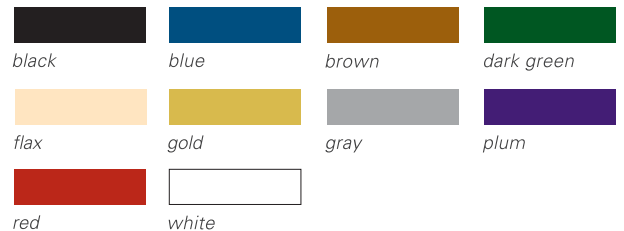

Table-top risers are also available in a variety of sizes. See order form for details.

display cylinders

Black

low

30"W 15"H – N75020

medium

18"W 20"H – N75021

high

24"W 36"H – N75022



orion computer kiosk

Black

28"L 28"D 40.5"H – N75079

Pedestal for computer demo with keyboard tray and interior storage. (Computer not included.)



display cubes

Black

12" small

12"W 12"L 42"H – N75030

18" medium

18"W 18"L 36"H – N75031

24" large

24"W 24"L 42"H – N75032



display counter

Black

24"W 49"L 42"H – N72056



accessories

We know that every exhibit is different and requires certain pieces that may be hard to find. That's why we offer an assortment of accessories that will meet your needs, from literature racks to bulletin boards to refrigerators and file cabinets. No matter the requirement, your exhibit will always stand out with these striking and functional pieces.

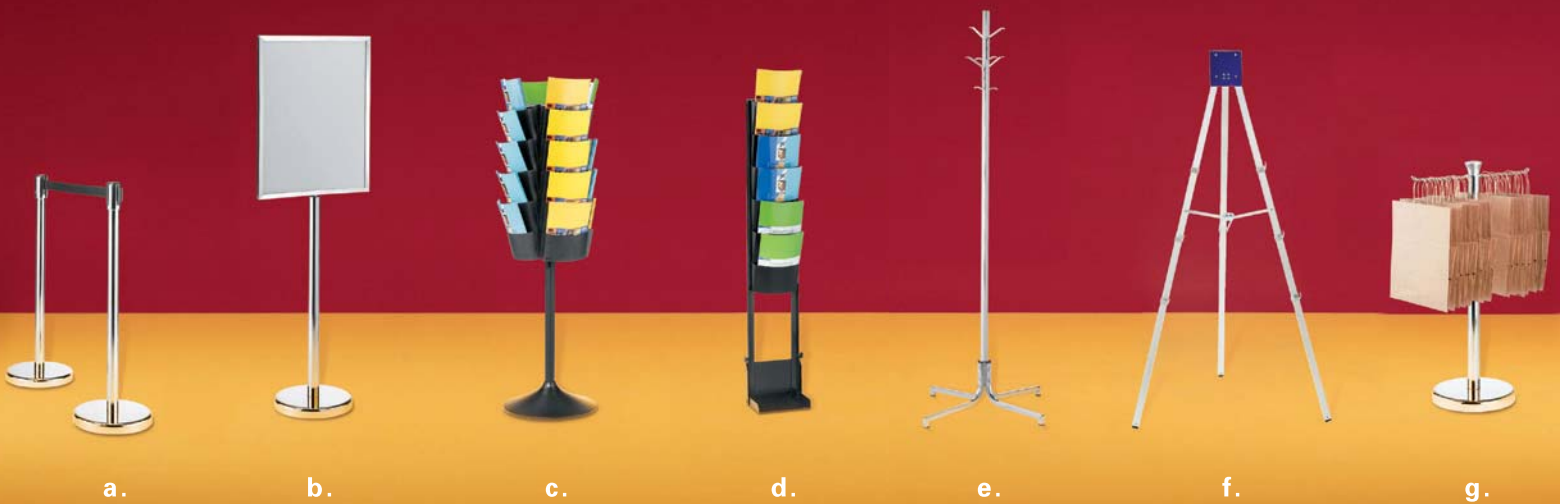

a. chrome stanchion with 8' retractable belt

42"H – C220121

b. chrome sign holder

Holds 22"x 28" sign – C220118

c. round literature rack

17"W 17"L 57"H – N750135

Revolving black display holds printed materials for easy access from 20 pockets.

d. flat literature rack

10"W 55"H – N750136

Forward-facing black display presents printed materials in six pockets.

e. chrome coat tree

C220109

f. chrome easel

C220134

g. chrome bag rack

C220110

special draping

(not pictured)

Special drape is available in a variety of colors. Refer to the order form for details.

accessories

file cabinet with lock

Standard Size

two-drawer

15"W 29"L 28"H – N74082

four-drawer

15"W 29"L 50"H – N74081



floor-standing bulletin board

48"W 96"L 78"H – C10201484



table lamp*

Black

25"H – N75052



small refrigerator*

19"W 19"L 34"H – N75057



wastebasket

Wastebasket color may vary.

C220107



corrugated wastebasket

C220106



*Note: Electrical power must be ordered separately.

FREEMAN

841 Joseph E. Lowery Blvd N W
Atlanta, GA 30318
(404) 253-6494 Fax: (469) 621-5610
FreemanAtlantaES@freemanco.com

**ONLINE PRICE
DISCOUNT PRICE
OCTOBER 14, 2016**

**INCLUDE THE FREEMAN METHOD OF
PAYMENT FORM WITH YOUR ORDER**

NAME OF SHOW: **PFA 57TH ANNUAL SYMPOSIUM AND EXPO / NOVEMBER 04 - 05, 2016**

COMPANY NAME: _____ BOOTH #: _____

CONTACT NAME: _____ PHONE #: _____

E-MAIL ADDRESS: _____

For Assistance, please call 404-253-6494 to speak with one of our experts.

For fast, easy ordering, go to www.freemanco.com/store

Qty	Part #	Description	Online Price	Discount Price	Standard Price	Total
CHAIRS						
_____	N71092	Diva Counter Stool	\$222.80	\$245.10	\$311.90	_____
_____	N71091	Diva Chair	\$193.20	\$212.50	\$270.50	_____
_____	N71048	Gray Gaslift Stool w/Arms ...	\$262.65	\$288.90	\$367.70	_____
_____	N71047	Gray Gaslift Stool	\$234.50	\$257.95	\$328.30	_____
_____	N71046	Gray Gaslift Chair w/Arms...	\$210.00	\$231.00	\$294.00	_____
_____	N71045	Gray Gaslift Chair	\$179.85	\$197.85	\$251.80	_____
_____	N71089	Black Diamond Side Chair .	\$137.75	\$151.55	\$192.85	_____
_____	N71090	Black Diamond Armchair	\$158.55	\$174.40	\$221.95	_____
_____	N71088	Black Diamond Stool	\$187.00	\$205.70	\$261.80	_____
_____	C210108	Limerick® Chair by Herman Miller.....	\$74.20	\$81.60	\$103.90	_____
_____	C210109	Limerick® Stool by Herman Miller.....	\$126.85	\$139.55	\$177.60	_____

TABLES						
_____	C115103	Studio Black Cocktail Table ...	\$93.05	\$102.35	\$130.25	_____
_____	C115104	Studio Black End Table	\$93.05	\$102.35	\$130.25	_____

Pedestal Tables - SoHo Series						
_____	N72066	Black-Top Mini 18"H x 18"W.....	\$148.60	\$163.45	\$208.05	_____
_____	N72069	Black-Top Cafe 30"H x 24"W.....	\$250.70	\$275.75	\$351.00	_____
_____	N72070	Black-Top Bistro 42"H x 24"W ...	\$250.70	\$275.75	\$351.00	_____
_____	N72067	Black-Cafe Table 30"H x 36"W ..	\$250.70	\$275.75	\$351.00	_____
_____	N72068	Black-Bistro Table 42"H x 36"W.	\$250.70	\$275.75	\$351.00	_____

Pedestal Tables - Chelsea Series - Butcher Block Top						
_____	N72063	Cafe Table 30"H x 30"W	\$191.55	\$210.70	\$268.15	_____
_____	N72064	Cafe Table 30"H x 36"W	\$191.55	\$210.70	\$268.15	_____
_____	N720163	Bistro Table 42"H x 30"W	\$191.55	\$210.70	\$268.15	_____
_____	N720164	Bistro Table 42"H x 36"W	\$191.55	\$210.70	\$268.15	_____

DISPLAY FURNITURE						
_____	N72056	Display Counter	\$356.90	\$392.60	\$499.65	_____
_____	N75079	Orion Computer Kiosk	\$433.25	\$476.60	\$606.55	_____
_____	N75030	Black Display Cube/Small ...	\$222.80	\$245.10	\$311.90	_____
_____	N75031	Black Display Cube/Med.....	\$242.05	\$266.25	\$338.85	_____
_____	N75032	Black Display Cube/Large ...	\$281.00	\$309.10	\$393.40	_____
_____	N75020	Black Display Cylinder/Low ..	\$212.05	\$233.25	\$296.85	_____
_____	N75021	Black Display Cylinder/Med..	\$245.45	\$270.00	\$343.65	_____
_____	N75022	Black Display Cylinder/High .	\$281.70	\$309.85	\$394.40	_____

Qty	Part #	Description	Online Price	Discount Price	Standard Price	Total
DISPLAY FURNITURE (continued)						
Draped Tables - Tables are 24" wide						
<input type="checkbox"/> Black <input type="checkbox"/> Blue <input type="checkbox"/> Brown <input type="checkbox"/> Dark Green <input type="checkbox"/> Flax <input type="checkbox"/> Gold <input type="checkbox"/> Gray <input type="checkbox"/> Plum <input type="checkbox"/> Red <input type="checkbox"/> White						
_____	C130330	Draped Table 3'L x 30"H.....	\$114.35	\$125.80	\$160.10	_____
_____	C130430	Draped Table 4'L x 30"H.....	\$137.75	\$151.55	\$192.85	_____
_____	C130630	Draped Table 6'L x 30"H.....	\$161.15	\$177.25	\$225.60	_____
_____	C130830	Draped Table 8'L x 30"H	\$184.50	\$202.95	\$258.30	_____
_____	C12404630	4th Side Drap 6' x 30"H ...	\$52.20	\$57.40	\$73.10	_____
_____	C12404830	4th Side Drap 8' x 30"H ...	\$52.20	\$57.40	\$73.10	_____
_____	C130342	Draped Counter 3'L x 42"H... \$155.25	\$170.80	\$217.35	_____	
_____	C130442	Draped Counter 4'L x 42"H... \$178.65	\$196.50	\$250.10	_____	
_____	C130642	Draped Counter 6'L x 42"H... \$202.05	\$222.25	\$282.85	_____	
_____	C130842	Draped Counter 8'L x 42"H... \$225.45	\$248.00	\$315.65	_____	
_____	C12404642	4th Side Drap 6' x 42"H.... \$52.20	\$57.40	\$73.10	_____	
_____	C12404842	4th Side Drap 8' x 42"H.... \$52.20	\$57.40	\$73.10	_____	

Undraped Tables - Tables are 24" wide						
_____	C131330	Undraped Table 3'L x 30"H.....	\$57.10	\$62.80	\$79.95	_____
_____	C131430	Undraped Table 4'L x 30"H.....	\$64.10	\$70.50	\$89.75	_____
_____	C131630	Undraped Table 6'L x 30"H.....	\$73.50	\$80.85	\$102.90	_____
_____	C131830	Undraped Table 8'L x 30"H.....	\$81.65	\$89.80	\$114.30	_____
_____	C131342	Undraped Counter 3'L x 42"H \$81.65	\$89.80	\$114.30	_____	
_____	C131442	Undraped Counter 4'L x 42"H \$97.95	\$107.75	\$137.15	_____	
_____	C131642	Undraped Counter 6'L x 42"H \$114.40	\$125.85	\$160.15	_____	
_____	C131842	Undraped Counter 8'L x 42"H \$130.70	\$143.75	\$183.00	_____	

Table Top Corrugated Risers						
_____	C1504100	Black 4'L x 7"H Corrugated Riser	\$30.40	\$33.45	\$42.55	_____
_____	C1504101	White 4'L x 7"H Corrugated Riser	\$30.40	\$33.45	\$42.55	_____
_____	C1506100	Black 6'L x 7"H Corrugated Riser	\$35.60	\$39.15	\$49.85	_____
_____	C1506101	White 6'L x 7"H Corrugated Riser	\$35.60	\$39.15	\$49.85	_____
_____	C1508100	Black 8'L x 7"H Corrugated Riser	\$41.10	\$45.20	\$57.55	_____
_____	C1508101	White 8'L x 7"H Corrugated Riser	\$41.10	\$45.20	\$57.55	_____

**Remember to select a color for items with checkboxes.
A color will be selected for you if not indicated.**

FREEMAN furnishing essentials 2

Take advantage of the Online price
by ordering at www.freemanco.com/store
by OCTOBER 14, 2016

COMPANY NAME: _____ BOOTH #: _____

CONTACT NAME: _____ PHONE #: _____

E-MAIL ADDRESS: _____

For Assistance, please call 404-253-6494 to speak with one of our experts.

For fast, easy ordering, go to www.freemanco.com/store

Qty	Part #	Description	Online Price	Discount Price	Standard Price	Total
DISPLAY FURNITURE (continued)						

Table Top Corrugated Risers						
_____	C1504200	Black 4'L x 14"H				
		Corrugated Riser	\$46.55	\$51.20	\$65.15	_____
_____	C1504201	White 4'L x 14"H				
		Corrugated Riser	\$46.55	\$51.20	\$65.15	_____
_____	C1506200	Black 6'L x 14"H				
		Corrugated Riser	\$56.95	\$62.65	\$79.75	_____
_____	C1506201	White 6'L x 14"H				
		Corrugated Riser	\$56.95	\$62.65	\$79.75	_____
_____	C1508200	Black 8'L x 14"H				
		Corrugated Riser	\$67.35	\$74.10	\$94.30	_____
_____	C1508201	White 8'L x 14"H				
		Corrugated Riser	\$67.35	\$74.10	\$94.30	_____

ACCESSORIES						
_____	C220121	Chrome Stanchion w/belt	\$99.55	\$109.50	\$139.35	_____
_____	C220118	Chrome Sign Holder	\$102.65	\$112.90	\$143.70	_____
_____	N750135	Round Literature Rack	\$251.70	\$276.85	\$352.40	_____
_____	N750136	Flat Literature Rack	\$231.55	\$254.70	\$324.15	_____
_____	C220109	Chrome Coat Tree	\$65.45	\$72.00	\$91.65	_____
_____	C220134	Chrome Easel	\$42.00	\$46.20	\$58.80	_____
_____	C220110	Chrome Bag Rack	\$116.90	\$128.60	\$163.65	_____
_____	C220106	Corrugated Wastebasket	\$22.00	\$24.20	\$30.80	_____
_____	N75057	Small Refrigerator	\$435.45	\$479.00	\$609.65	_____
_____	N74082	File Cabinet/2 Drawer	\$134.00	\$147.40	\$187.60	_____
_____	N74081	File Cabinet/4Drawer	\$176.05	\$193.65	\$246.45	_____
_____	C10201484	Bulletin Board	\$209.15	\$230.05	\$292.80	_____

Special Drape	
<input type="checkbox"/> Black	<input type="checkbox"/> Blue <input type="checkbox"/> Brown <input type="checkbox"/> Dark Green <input type="checkbox"/> Flax
<input type="checkbox"/> Gold	<input type="checkbox"/> Gray <input type="checkbox"/> Plum <input type="checkbox"/> Red <input type="checkbox"/> White

_____	12103	Special Drape 3'H (per ft.)	\$20.05	\$22.05	\$28.05	_____
_____	12108	Special Drape 8'H (per ft.)	\$27.60	\$30.35	\$38.65	_____

TOTAL COST		
Sub-Total _____	+ Tax (6%) _____	= TOTAL _____

**Remember to select a color for items with checkboxes.
A color will be selected for you if not indicated.**

FREEMAN furnishing essentials 2

Take advantage of the Online price
by ordering at www.freemanco.com/store
by OCTOBER 14, 2016



SELECT furnishings2

seating

Sit back and relax – your search for comfortable seating is over. Choose from a sleek selection of sofas, loveseats and chairs that are sure to take your exhibit design to the next level.

naples



chair

Black Leather

36" L 30" D 28" H – 810119

⚡ Powered option – 810120



loveseat

Black Leather

62" L 30" D 28" H – 830120

⚡ Powered option – 830122



sofa

Black Leather

87" L 30" D 28" H – 830119

⚡ Powered option – 830121

heathrow

possible configurations:

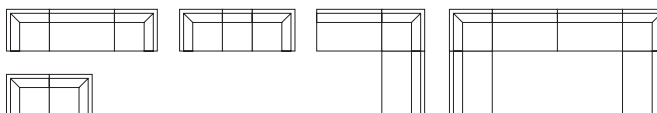

armless chair

Black Leather

24" L 24" D 28" H – 810116



corner chair

Black Leather

24" L 24" D 28" H – 810117



sofa

Black Leather

48" L 24" D 28" H – 830116

⚡ See pages 15 and 16 for all Powered options.

south beach

possible configurations (featuring the half round ottomans from page 5):

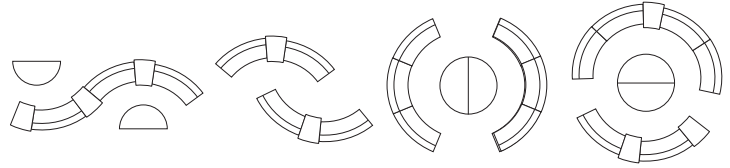

sofa

Platinum Suede
69" L 29"D 33"H – 8301



ottoman

Platinum Suede
25" L 31" D 18" H – 8151

key west



loveseat

Black Fabric
57" L 35" D 33" H – 8307



sofa

Black Fabric
85" L 35" D 33" H – 8306



tub chair

Black Fabric
31" L 31" D 31" H – 8103

seating



allegro

chair

Blue Fabric
36" L 34.5" D 30" H – 81019

sofa

Blue Fabric
73" L 34.5" D 29.5" H – 83015



tangiers

chair

Beige Fabric
34" L 37" D 36" H – 810118

sofa

Beige Fabric
78" L 37" D 36" H – 830118



roma

chair

White Vinyl
37" L 31" D 33" H – 81020
⚡ Powered option – 81021

sofa

White Vinyl
78" L 31" D 33" H – 83016
⚡ Powered option – 83017



⚡ See pages 15 and 16 for all Powered options.

casual seating

Look no further for a great variety of informal, modern seating options. Here you will find chairs, sofas, stools, ottomans – even sophisticated bar sets – that turn exhibits into destinations.

ottomans

endless square

Black Leather – 815123

White Leather – 815122

34" L 34" D 15" H



half round ottoman

White Leather – 81514

Black Leather – 81513

72" L 36" D 17" H



ottoman bench

Black Leather – 815121

White Leather – 815120

60" L 20" D 18" H



leather cube

Black Leather – 81512

White Leather – 81511

17" L 17" D 18" H



edge LED cube

High Density Plastic

20" L 20" D 20" H – 81526



ottomans

vibe cube

Blue Vinyl – 81518
 Pink Vinyl – 81520
 Red Vinyl – 81519
 Yellow Vinyl – 81517
 Orange Vinyl – 81525
 18”L 18”D 18”H



occasional chairs

madrid chair

Black Leather/Chrome
 30”L 30”D 31”H – 8102



madrid chair

White Leather/Chrome
 30”L 30”D 31”H – 810816



meeting chair (espresso)

Bonded Leather/Wood Legs
 25.5”L 23.5”D 34”H – 810835



meeting chair (taupe)

Microfiber/Wood Legs
 25.5”L 23.5”D 34”H – 810836



occasional chairs

t-vac chair

Translucent/Chrome Legs
25"L 23"D 30"H – 8101



swanson chair

White Vinyl
28"L 25"D 18"H – 810875



ICE side chair

Transparent/Chrome Legs
17.25"L 20"D 32"H – 810814



fusion chair (white/black)

White/Black High Density Plastic
19"L 21"D 32"H – 810838



christopher chair

White Vinyl/Chrome
17"L 19"D 35"H – 810846



rustique chair with arms

Gunmetal
20"L 18"D 31"H – 810841



occasional chairs

razor armless chair

White High Density Plastic
15.38" L 15.5" D 30.5" H – 810837



new york chair

Onyx/Maple Wood/Chrome
23" L 32" D 33" H – 81090



panton chair

White Plastic
20" L 24" D 33" H – 81017



madden chair

Light Gray Vinyl
27" L 32" D 33" H – 810843



wendy chair

Clear Acrylic
15" L 19.7" D 35.8" H – 810847



berlin stack chair

White & Red Plastic/Chrome – 810811
White & Black Plastic/Chrome – 810810
18" L 22" D 32" H



conference chairs

luxor executive chair

Black Leather

27" L 28" D 47" H

Adjustable – 810807



labrea chair

Charcoal Gray Fabric

35" L 27" D 40" H – 810874



pro executive chair

White Vinyl

27.5" L 27.5" D 45.7" H – 810844



perth highback chair

Black Leather/Chrome

23" L 21" D 43" H

Adjustable – 810813



altura conference/ guest chair

Black Fabric/Black Steel

25" L 20" D 34" H – 81063



flex chair

Black Plastic/Chrome

24" L 22" D 31" H – 81018



altura junior executive chair

Black Fabric

25" L 25" D 37" H

Adjustable – 81073



bars & barstools

martini bar

Gray metal rounded bar with frosted glass top and chrome legs
67" L 50" D 47" H – Radius 76.5" – 8501

possible configurations:

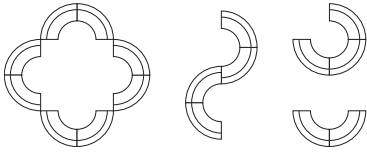

lift hydraulic barstool

Gray Vinyl/Chrome – 810872
Red Vinyl/Chrome – 810873
Black Vinyl/Chrome – 810871
White Vinyl/Chrome – 810870
15" Round 23-33.5" H Adjustable



Tables in coordinating colors are available upon request.

bars & barstools

banana barstool

White Vinyl/Chrome – 810103

Black Vinyl/Chrome – 810104

21" L 22" D 30" H



zoey barstool

White Vinyl/Chrome – 810840

Black Vinyl/Chrome – 810834

15" L 17" D 31-35" H



ICE barstool

Transparent/Chrome Legs

16.75" L 16" D 37.75" H – 810815



jetson barstool

Black Vinyl/Black Steel

18" L 19" D 29" H – 810706



shark swivel barstool

White Plastic/Chrome

22" L 19" D 34-44" H

Adjustable – 810202



rustique barstool

Gunmetal

13" L 13" D 30" H – 810839



gin barstool

Maple Wood/Chrome

16" L 16" D 29" H – 810505



oslo barstool

Blue Plastic/Chrome – 810200

White Plastic/Chrome – 810201

17" L 20" D 30" H



tables

Bring professionalism to the table with our sleek variety of surfaces and tabletops. Choose from modern glass tops and more.

occasional end & cocktail tables



inspiration

end table

Tempered Glass/Painted Steel
24" L 28" D 22" H – 82023

table

Tempered Glass/Painted Steel
42" L 28" D 18" H – 82022



geo

end table

Glass/Black Steel – 82025
Glass/Chrome – 82035
26" L 26" D 20" H

table

Glass/Black Steel – 82024
Glass/Chrome – 82034
50" L 22" D 16" H



sydney

end table

Black Laminate/Brushed Steel – 82054
White Laminate/Brushed Steel – 82055
27" L 23" D 22" H

table

Black Laminate/Brushed Steel – 82052
White Laminate/Brushed Steel – 82053
48" L 24" D 18" H



silverado

end table

Tempered Glass/Painted Steel
24" Round 22" H – 82015

table

Tempered Glass/Painted Steel
36" Round 17" H – 82014



occasional end & cocktail tables



oliver

end table

Walnut Finish
22" Round 22"H – 82088

table

Walnut Finish
47"L 27"D 19"H – 82087



geo square-round table

Glass/Black Steel – 82043

Glass/Chrome – 82044

42"L 42"D 29"H



candy table

White Plastic/Black Laminated Top

18"L 18"D 18"H – 82056



aura round table

White Metal

15" Round 22"H – 820844



edge LED lighted table

White Plastic/Clear Acrylic Top

20"L 20"D 20"H – 82057



conference tables

nova white oval table

White Laminate/Chrome
71" L 35.5" D 29" H – 82060



geo conference table

Glass/Black Steel – 82041
Glass/Chrome – 82051
60" L 36" D 29" H



communal table (maple with grommets)

Laminate/Metal
72" L 26" D 30" H – 82058
72" L 26" D 42" H – 82059



manhattan table

Glass/Black Steel
42" Round 29" H – 82033



communal table (maple)

Laminate/Metal
72" L 26" D 30" H – 82067
72" L 26" D 42" H – 82068



communal table (white)

Laminate/Metal
72" L 26" D 30" H – 82063
72" L 26" D 42" H – 82066



conference tables

8' rectangular conference table

Granite

96" L 46" D 29" H – 820115



6' oval conference table

Graphite Nebula

72" L 42" D 29" H – 820203



42" round white conference table

White Laminate

42" Round – 820708



office

executive desk

Mahogany

60" L 30" D 29" H – 898613



5 shelf bookcase

Mahogany

36" L 13" D 71" H – 898609



storage credenza

Mahogany

72" L 24" D 29" H – 898611



computer desk / table

work desk

White Laminate

48" L 24" D 30" H – 820706



merlin table

Gray Laminate

46" L 29" D 30" H – 820707





All powered options will have an adapter included with rental.
Additional adapters can be ordered separately.

powered seating

naples chair, powered*

Black Vinyl

36" L 30" D 28" H – 810120



power panel detail



naples loveseat, powered*

Black Vinyl

62" L 30" D 28" H – 830122



power panel detail



naples sofa, powered*

Black Vinyl

87" L 30" D 28" H – 830121



power panel detail



roma chair, powered*

White Vinyl

37" L 31" D 33" H – 81021



power panel detail



roma sofa, powered*

White Vinyl

78" L 31" D 33" H – 83017



power panel detail



*Electrical power must be ordered separately.

powered tables

G30 cocktail table, powered*

White Top

72" L 26" D 18" H – 82070



G30 café table, powered*

White Top

72" L 26" D 30" H – 82071



G30 bar table, powered*

White Top

72" L 26" D 42" H – 82072



powered product pedestals

powered locking pedestal, 36"

Black – 85060

White – 85061

24" L 24" D 36" H

powered locking pedestal, 42"

Black – 85062

White – 85063

24" L 24" D 42" H



power panel detail



adapters

4-way charging adapter*

Black – 850800

White – 850801

36" L

All powered options will have one adapter included per power panel. Additional adapters can be ordered with the rental.



*Electrical power must be ordered separately.

product display

etagere

Black – 850604
Pewter – 850605
30" L 16" D 70" H



locking door pedestal

Black Laminate
24" L 24" D 42" H – 85078
⚡ Powered Option – 85062



lighting

mason table lamp*

White/Brushed Silver
16" Round 26" H – 850707



mason floor lamp*

White/Brushed Silver
18" Round 55" H – 850708



refrigerators

refrigerator*

White
14.0 cubic feet
20" L 30" D 65" H – 8503001



*Electrical power must be ordered separately.

⚡ See pages 15 and 16 for all Powered options.

tablet stand

mobile tablet stand

White – 850714

Black – 850715

14"L 13"D 44.5"H

The Mobile Tablet Stand will adjust to fit any tablet with dimensions of at least 6.75" x 9.375" but not larger than 8.5" x 12.5", including Apple iPad, Samsung Galaxy Tab and Lenovo IdeaPad.



tablet stand accessories

brochure holder*

Black – 850711

8.625"L 1.1"D 11.325"H



wireless printer holder*

Black – 850712

3.3"L 1.9"D 5.28"H



charging shelf*

Black – 850713

14.85"L 7.17"D 1"H



*To be ordered with the tablet stand.

FREEMAN

841 Joseph E. Lowery Blvd N W
 Atlanta, GA 30318
 (404) 253-6494 Fax: (469) 621-5610
 FreemanAtlantaES@freemanco.com

**ONLINE PRICE
 DISCOUNT PRICE
 OCTOBER 14, 2016**

**INCLUDE THE FREEMAN METHOD OF
 PAYMENT FORM WITH YOUR ORDER**

NAME OF SHOW: **PFA 57TH ANNUAL SYMPOSIUM AND EXPO / NOVEMBER 04 - 05, 2016**

COMPANY NAME: _____ BOOTH #: _____

CONTACT NAME: _____ PHONE #: _____

E-MAIL ADDRESS: _____

For Assistance, please call 404-253-6494 to speak with one of our experts.

For fast, easy ordering, go to www.freemanco.com/store

Qty	Part #	Description	Online Price	Discount Price	Standard Price	Total
SEATING						
Naples Group - Black Leather						
_____	810119	Chair	\$375.50	\$413.05	\$525.70	\$ _____
_____	830120	Loveseat	\$503.55	\$553.90	\$704.95	\$ _____
_____	830119	Sofa	\$558.75	\$614.65	\$782.25	\$ _____
Heathrow Group - Black Leather						
_____	810116	Armless Chair	\$284.35	\$312.80	\$398.10	\$ _____
_____	810117	Corner Chair	\$331.45	\$364.60	\$464.05	\$ _____
_____	830116	Sofa	\$481.45	\$529.60	\$674.05	\$ _____
South Beach Group - Platinum Suede						
_____	8301	Sofa	\$521.50	\$573.65	\$730.10	\$ _____
_____	8151	Ottoman	\$227.90	\$250.70	\$319.05	\$ _____
Key Largo Group - Black Fabric						
_____	830950	Loveseat	\$382.85	\$421.15	\$536.00	\$ _____
_____	830951	Sofa	\$423.70	\$466.05	\$593.20	\$ _____
_____	810950	Chair	\$301.90	\$332.10	\$422.65	\$ _____
Allegro Group - Blue Fabric						
_____	81019	Chair	\$411.35	\$452.50	\$575.90	\$ _____
_____	83015	Sofa	\$656.65	\$722.30	\$919.30	\$ _____
Fairfax Group - White Vinyl						
_____	810949	Chair	\$254.60	\$280.05	\$356.45	\$ _____
_____	830949	Sofa	\$406.35	\$447.00	\$568.90	\$ _____
Tangiers Group - Beige Fabric						
_____	810118	Chair	\$332.75	\$366.05	\$465.85	\$ _____
_____	830118	Sofa	\$466.25	\$512.90	\$652.75	\$ _____
Roma Group - White Vinyl						
_____	81020	Chair	\$460.40	\$506.45	\$644.55	\$ _____
_____	83016	Sofa	\$705.75	\$776.35	\$988.05	\$ _____

CASUAL SEATING

Ottomans						
_____	815123	Endless Square - Black Leather	\$240.75	\$264.85	\$337.05	\$ _____
_____	815122	Endless Square - White Leather	\$240.75	\$264.85	\$337.05	\$ _____
_____	815952	Endless Curved - Black Leather	\$314.50	\$345.95	\$440.30	\$ _____
_____	815953	Endless Curved - White Leather	\$314.50	\$345.95	\$440.30	\$ _____
_____	815121	Bench - Black Leather	\$289.60	\$318.55	\$405.45	\$ _____
_____	815120	Bench - White Leather	\$289.60	\$318.55	\$405.45	\$ _____
Cubes						
_____	81512	Leather Cube - Black Leather	\$90.65	\$99.70	\$126.90	\$ _____
_____	81511	Leather Cube - White Leather	\$90.65	\$99.70	\$126.90	\$ _____
_____	81526	Edge LED Cube Ottoman - High Density Plastic	\$159.70	\$175.65	\$223.60	\$ _____
_____	81518	Vibe - Blue Vinyl	\$117.00	\$128.70	\$163.80	\$ _____
_____	81520	Vibe - Pink Vinyl	\$117.00	\$128.70	\$163.80	\$ _____
_____	81519	Vibe - Red Vinyl	\$117.00	\$128.70	\$163.80	\$ _____
_____	81517	Vibe - Yellow Vinyl	\$117.00	\$128.70	\$163.80	\$ _____
_____	81525	Vibe - Orange Vinyl	\$117.00	\$128.70	\$163.80	\$ _____
Occasional Chairs						
_____	8102	Madrid Chair - Black Leather	\$651.50	\$716.65	\$912.10	\$ _____
_____	810816	Madrid Chair - White Leather	\$651.50	\$716.65	\$912.10	\$ _____
_____	810948	Meeting Chair - White Vinyl	\$209.65	\$230.60	\$293.50	\$ _____
_____	810835	Meeting Chair - Espresso Leather	\$168.75	\$185.65	\$236.25	\$ _____
_____	810836	Meeting Chair - Taupe Microfiber	\$221.35	\$243.50	\$309.90	\$ _____
_____	810847	Wendy Chair - Clear Acrylic	\$91.85	\$101.05	\$128.60	\$ _____
_____	810875	Swanson Chair - White Vinyl	\$204.60	\$225.05	\$286.45	\$ _____
_____	810814	ICE Side Chair - Transparent/Chrome	\$171.85	\$189.05	\$240.60	\$ _____
_____	810838	Fusion Chair Black/White	\$116.10	\$127.70	\$162.55	\$ _____
_____	810837	Razor Armless Chair - High Density Plastic	\$45.35	\$49.90	\$63.50	\$ _____
_____	81090	New York Chair - Onyx/Maple Wood/Chrome	\$153.90	\$169.30	\$215.45	\$ _____
_____	8103	Tub Chair - Black Fabric	\$325.80	\$358.40	\$456.10	\$ _____
_____	810843	Madden Chair - Light Gray Vinyl	\$344.75	\$379.25	\$482.65	\$ _____
_____	810846	Christopher Chair - White Vinyl/Chrome	\$93.40	\$102.75	\$130.75	\$ _____

FREEMAN select furnishings

Take advantage of the Online price
 by ordering at www.freemanco.com/store
 by OCTOBER 14, 2016

COMPANY NAME: _____ BOOTH #: _____

CONTACT NAME: _____ PHONE #: _____

E-MAIL ADDRESS: _____

For Assistance, please call 404-253-6494 to speak with one of our experts.

For fast, easy ordering, go to www.freemanco.com/store

Qty	Part #	Description	Online Price	Discount Price	Standard Price	Total
-----	--------	-------------	--------------	----------------	----------------	-------

CASUAL SEATING

Occasional Chairs (continued)

_____	810841	Rustique Chair with Arms - Gunmetal.....	\$93.40	\$102.75	\$130.75	\$
_____	810811	Berlin Stack Chair - White & Red Plastic/Chrome.....	\$88.30	\$97.15	\$123.60	\$
_____	810810	Berlin Stack Chair - White & Black Plastic/Chrome.....	\$88.30	\$97.15	\$123.60	\$

Conference Chairs

_____	810874	Labrea Chair - Charcoal Gray Fabric.....	\$240.25	\$264.30	\$336.35	\$
_____	810773	Altura Junior Executive Chair - Black Fabric.....	\$286.40	\$315.05	\$400.95	\$
_____	81063	Altura Conference/Guest Chair - Black Fabric/Black... Steel	\$261.35	\$287.50	\$365.90	\$
_____	810807	Luxor Executive Chair - Black Leather.....	\$346.05	\$380.65	\$484.45	\$
_____	810945	Pro Executive Mid Back Chair - White Vinyl.....	\$260.10	\$286.10	\$364.15	\$
_____	810947	Pro Executive Guest Chair - Black Vinyl.....	\$271.25	\$298.40	\$379.75	\$
_____	810844	Pro Executive High Back Chair - White Vinyl.....	\$212.80	\$234.10	\$297.90	\$
_____	810946	Pro Executive High Back Chair - Black Vinyl.....	\$209.60	\$230.55	\$293.45	\$

Bars & Bar Stools

_____	8501	Martini Bar - Grey metal rounded bar with frosted glass top and chrome legs	\$1140.70	\$1254.75	\$1597.00	\$
_____	810872	Lift Hydraulic Barstool - Grey Vinyl/Chrome.....	\$123.85	\$136.25	\$173.40	\$
_____	810873	Lift Hydraulic Barstool - Red Vinyl/Chrome.....	\$123.85	\$136.25	\$173.40	\$
_____	810871	Lift Hydraulic Barstool - Black Vinyl/Chrome.....	\$123.85	\$136.25	\$173.40	\$
_____	810870	Lift Hydraulic Barstool - White Vinyl/Chrome.....	\$123.85	\$136.25	\$173.40	\$
_____	33010	Apex Barstool - Black Vinyl.....	\$151.65	\$166.80	\$212.30	\$
_____	3309	Apex Barstool - Blue Ultra Suede.....	\$151.65	\$166.80	\$212.30	\$
_____	33042	Apex Barstool - Red Vinyl.....	\$151.65	\$166.80	\$212.30	\$
_____	33043	Apex Barstool - White Vinyl.....	\$151.65	\$166.80	\$212.30	\$
_____	810815	ICE Barstool - Transparent/Chrome.....	\$183.80	\$202.20	\$257.30	\$
_____	810839	Rustique Barstool - Gunmetal.....	\$93.40	\$102.75	\$130.75	\$
_____	810202	Shark Swivel Barstool - White Plastic/Chrome.....	\$275.50	\$303.05	\$385.70	\$
_____	810848	Christopher Barstool - White.....	\$155.65	\$171.20	\$217.90	\$
_____	810706	Jetson Barstool - Black Vinyl/Black Steel.....	\$214.80	\$236.30	\$300.70	\$
_____	810505	Gin Barstool - Maple Wood/Chrome.....	\$137.30	\$151.05	\$192.20	\$
_____	810200	Oslo Barstool - Blue Plastic/Chrome.....	\$195.75	\$215.35	\$274.05	\$
_____	810201	Oslo Barstool - White Plastic/Chrome.....	\$195.75	\$215.35	\$274.05	\$
_____	810834	Zoey Barstool - Black Vinyl/Chrome.....	\$241.30	\$265.45	\$337.80	\$
_____	810840	Zoey Barstool - White Vinyl/Chrome.....	\$241.30	\$265.45	\$337.80	\$
_____	810104	Banana Barstool - Black Vinyl/Chrome.....	\$155.10	\$170.60	\$217.15	\$
_____	810103	Banana Barstool - White Vinyl/Chrome.....	\$155.10	\$170.60	\$217.15	\$

TABLES

Occasional End & Cocktail Tables

_____	82023	Inspiration End Table - Tempered Glass/Painted Steel.....	\$241.00	\$265.10	\$337.40	\$
_____	82022	Inspiration Table - Tempered Glass/Painted Steel.....	\$254.20	\$279.60	\$355.90	\$
_____	82025	Geo End Table - Glass/Black Steel.....	\$188.50	\$207.35	\$263.90	\$
_____	82035	Geo End Table - Glass/Chrome.....	\$188.50	\$207.35	\$263.90	\$
_____	82024	Geo Table - Glass/Black Steel.....	\$208.85	\$229.75	\$292.40	\$
_____	82034	Geo Table - Glass/Chrome.....	\$208.85	\$229.75	\$292.40	\$
_____	82054	Sydney End Table - Black Laminate/Brushed Steel.....	\$194.50	\$213.95	\$272.30	\$
_____	82055	Sydney End Table - White Laminate/Brushed Steel.....	\$194.50	\$213.95	\$272.30	\$
_____	82052	Sydney Table - Black Laminate/Brushed Steel.....	\$235.10	\$258.60	\$329.15	\$
_____	82053	Sydney Table - White Laminate/Brushed Steel.....	\$235.10	\$258.60	\$329.15	\$
_____	82088	Oliver End Table - Walnut Finish.....	\$173.55	\$190.90	\$242.95	\$
_____	82087	Oliver Table - Walnut Finish.....	\$195.90	\$215.50	\$274.25	\$
_____	82015	Silverado End Table - Tempered Glass/Painted Steel.....	\$208.85	\$229.75	\$292.40	\$
_____	82014	Silverado Table - Tempered Glass/Painted Steel.....	\$221.95	\$244.15	\$310.75	\$
_____	82075	Regis End Table - Brushed Metal.....	\$176.55	\$194.20	\$247.15	\$
_____	82074	Regis Bench Table - Brushed Metal.....	\$249.65	\$274.60	\$349.50	\$
_____	82043	Geo Square-Round Table - Glass/Black Steel.....	\$286.40	\$315.05	\$400.95	\$
_____	82044	Geo Square-Round Table - Glass/Chrome.....	\$286.40	\$315.05	\$400.95	\$
_____	82056	Candy Table - White Plastic/Black Laminated.....	\$137.90	\$151.70	\$193.05	\$
_____	820844	Aura Round Table - White Metal.....	\$99.55	\$109.50	\$139.35	\$
_____	82057	Edge LED Cube Table - White Plastic/Clear Acrylic.....	\$159.70	\$175.65	\$223.60	\$

Conference Table

_____	82060	Nova White Oval Table - White Laminate/Chrome.....	\$471.80	\$519.00	\$660.50	\$
_____	82041	Geo Conference Table - Glass/Black Steel.....	\$352.00	\$387.20	\$492.80	\$
_____	82051	Geo Conference Table - Glass/Chrome.....	\$352.00	\$387.20	\$492.80	\$
_____	82067	Communal Table 30"H - Maple Solid.....	\$397.35	\$437.10	\$556.30	\$
_____	82068	Communal Table 42"H - Maple Solid.....	\$556.95	\$612.65	\$779.75	\$
_____	82063	Communal Table 30"H - White Solid.....	\$397.35	\$437.10	\$556.30	\$
_____	82066	Communal Table 42"H - White Solid.....	\$556.95	\$612.65	\$779.75	\$

COMPANY NAME: _____ BOOTH #: _____

CONTACT NAME: _____ PHONE #: _____

E-MAIL ADDRESS: _____

For Assistance, please call 404-253-6494 to speak with one of our experts.

For fast, easy ordering, go to www.freemanco.com/store

Qty	Part #	Description	Online Price	Discount Price	Standard Price	Total
Conference Tables (Continued)						
_____	82058	Communal Table 30" H (Maple with Grommets).....	\$397.35	\$437.10	\$556.30	\$ _____
_____	82059	Communal Table 42" H (Maple with Grommets).....	\$556.95	\$612.65	\$779.75	\$ _____
_____	82033	Manhattan Table - Glass/Black Steel.....	\$249.40	\$274.35	\$349.15	\$ _____
_____	820708	42" Round White Conference Table - White Laminate.	\$312.55	\$343.80	\$437.55	\$ _____
Office						
_____	84075	Madison Desk - Gray Acajou.....	\$443.35	\$487.70	\$620.70	\$ _____
_____	84078	Madison Bookcase - Gray Acajou.....	\$315.05	\$346.55	\$441.05	\$ _____
_____	84077	Madison Credenza - Gray Acajou.....	\$369.50	\$406.45	\$517.30	\$ _____
Computer / Desk / Table						
_____	820706	Work Desk - White Powder Coat.....	\$269.30	\$296.25	\$377.00	\$ _____
_____	820707	Merlin Table - Gray Laminate.....	\$280.10	\$308.10	\$392.15	\$ _____
POWERED						
Powered Seating						
_____	81021	Roma Chair, Powered - White Vinyl.....	\$512.20	\$563.40	\$717.10	\$ _____
_____	83017	Roma Sofa, Powered - White Vinyl.....	\$791.70	\$870.85	\$1108.40	\$ _____
_____	810120	Naples Chair, Powered - Black Vinyl.....	\$512.20	\$563.40	\$717.10	\$ _____
_____	830122	Naples Loveseat, Powered - Black Vinyl.....	\$687.70	\$756.45	\$962.80	\$ _____
_____	830121	Naples Sofa, Powered - Black Vinyl.....	\$791.70	\$870.85	\$1108.40	\$ _____
Powered Tables						
_____	84083	Tech Desk w/3 Drawer File Cabinet, Powered - Black Metal.....	\$458.55	\$504.40	\$641.95	\$ _____
_____	84084	Tech Desk, Powered - Black Metal.....	\$402.15	\$442.35	\$563.00	\$ _____
_____	82070	G30 Cocktail Table 18" H, Powered - White Top.....	\$336.70	\$370.35	\$471.40	\$ _____
_____	82071	G30 Cafe Table 30" H, Powered - White Top.....	\$466.70	\$513.35	\$653.40	\$ _____
_____	82072	G30 Bar Table 42" H, Powered - White Top.....	\$609.70	\$670.65	\$853.60	\$ _____
_____	82076	Sydney Cocktail Table, Powered - Black.....	\$311.30	\$342.45	\$435.80	\$ _____
_____	82073	Sydney Cocktail Table, Powered - White.....	\$311.30	\$342.45	\$435.80	\$ _____
Powered Product Display						
_____	85060	Powered Locking Pedestal 36" H - Black.....	\$373.35	\$410.70	\$522.70	\$ _____
_____	85061	Powered Locking Pedestal 36" H - White.....	\$373.35	\$410.70	\$522.70	\$ _____
_____	85062	Powered Locking Pedestal 42" H - Black.....	\$446.15	\$490.75	\$624.60	\$ _____
_____	85063	Powered Locking Pedestal 42" H - White.....	\$446.15	\$490.75	\$624.60	\$ _____
Adapters						
_____	850800	Charging Adapters Four - Black.....	\$20.80	\$22.90	\$29.10	\$ _____
_____	850801	Charging Adapters Four - White.....	\$20.80	\$22.90	\$29.10	\$ _____
PRODUCT DISPLAYS, TABLET STANDS & MORE						
Product Storage						
_____	84080	3 Door File Cabinet on Castors - Black.....	\$139.95	\$153.95	\$195.95	\$ _____
_____	85078	Locking Door Pedestal - Black Laminate.....	\$384.25	\$422.70	\$537.95	\$ _____
Product Display						
_____	850604	Etagere - Black.....	\$257.70	\$283.45	\$360.80	\$ _____
_____	850605	Etagere - Pewter.....	\$257.70	\$283.45	\$360.80	\$ _____
Refrigerator						
_____	8503001	Refrigerator - White.....	\$645.50	\$710.05	\$903.70	\$ _____
Lighting						
_____	850707	Mason Table Lamp - White/Brushed Silver.....	\$128.35	\$141.20	\$179.70	\$ _____
_____	850708	Mason Floor Lamp - White/Brushed Silver.....	\$190.65	\$209.70	\$266.90	\$ _____
Tablet Stands						
_____	850714	Mobile Tablet Stand - White.....	\$228.55	\$251.40	\$319.95	\$ _____
_____	850715	Mobile Tablet Stand - Black.....	\$228.55	\$251.40	\$319.95	\$ _____
Tablet Stand Accessories						
_____	850711	Brochure Holder - Black.....	\$22.70	\$24.95	\$31.80	\$ _____
_____	850712	Wireless Printer Holder - Black.....	\$22.70	\$24.95	\$31.80	\$ _____
_____	850713	Charging Shelf - Black.....	\$22.70	\$24.95	\$31.80	\$ _____

TOTAL COST		
Sub-Total _____	+ Tax (6%) _____	= TOTAL _____

FREEMAN

841 Joseph E. Lowery Blvd N W
Atlanta, GA 30318
(404) 253-6494 Fax: (469) 621-5610
FreemanAtlantaES@freemanco.com

**ONLINE PRICE
DISCOUNT PRICE
OCTOBER 14, 2016**

**INCLUDE THE FREEMAN METHOD OF
PAYMENT FORM WITH YOUR ORDER**

NAME OF SHOW: **PFA 57TH ANNUAL SYMPOSIUM AND EXPO / NOVEMBER 04 - 05, 2016**

COMPANY NAME: _____ BOOTH #: _____



CONTACT NAME: _____ PHONE #: _____

E-MAIL ADDRESS: _____

For Assistance, please call 404-253-6494 to speak with one of our experts.

For fast, easy ordering, go to www.freemanco.com/store

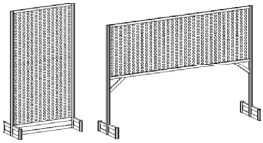
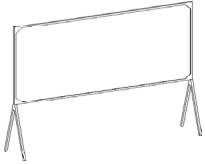
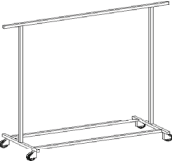
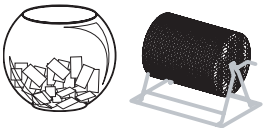
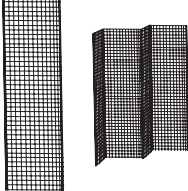
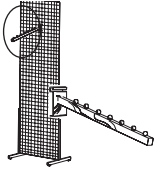
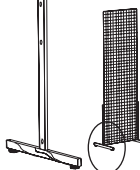
ACCESSORIES

<p>PERFBOARD-SINGLE SIDED Vertical Horizontal</p> 	<p>BULLETIN BOARD</p> 	<p>CHROME GARMENT RACK</p> 	<p>FISH BOWL</p>  <p>TICKET TUMBLER</p>
<p>2' x 8' GRID PANELS</p> 	<p>GRID ACCESSORIES</p> 	<p>GRID LEGS</p> 	<p>2-WAY STRAIGHT ARM</p>  <p>4-WAY SLANT ARM</p> 



HALF VISION SHOWCASE

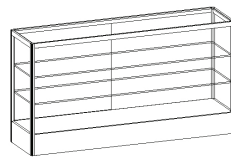

FULL VISION SHOWCASE

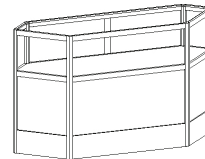

CORNER SHOWCASE

Qty	Part #	Description	Online Special Price	Discount Price	Standard Price	Total
PERFBOARD / BULLETIN BOARDS						
___	10201287	1/2M x 87" - Single Sided	\$126.95	139.65	177.75	_____
___	10201288	1/2M x 87" - Double Sided	\$177.95	195.75	249.15	_____
___	10201087	1M x 87" - Single Sided	\$202.50	222.75	283.50	_____
___	10201088	1M x 87" - Double Sided	\$252.55	277.80	353.55	_____
___	10201484	4'x8' -Bulletin Board/Horz....	\$209.15	230.05	292.80	_____
ACCESSORIES						
___	10406	Garment Rack	\$97.75	107.55	136.85	_____
___	15905	Fish Bowl	\$26.10	28.70	36.55	_____
___	159011	Ticket Tumbler - small	\$61.70	67.85	86.40	_____
___	10404	4-way Slant Arm	\$210.80	231.90	295.10	_____
___	10403	2-way Straight Arm	\$164.50	180.95	230.30	_____
GRIDS (continued)						
___	103028	Chrome - Grid	\$128.60	141.45	180.05	_____
___	103011	White - Grid	\$128.60	141.45	180.05	_____
___	103029	Chrome - Grid Legs	\$43.00	47.30	60.20	_____
___	103029	White - Grid Legs	\$43.00	47.30	60.20	_____
___	10307	7-Ball Waterfall (for grids).....	\$17.45	19.20	24.45	_____

Qty	Part #	Description	Online Special Price	Discount Price	Standard Price	Total
SHOWCASES						
___	175561	Full Vision Case	\$745.00	819.50	1043.00	_____
___	175560	Half Vision Case	\$669.55	736.50	937.35	_____
___	175563	Corner Case	\$575.55	633.10	805.75	_____
<p>FULL VISION CASE 79 1/2"L x 20 7/16"W x 42"H Includes two plexi-glass shelves with adjustable brackets and 32 3/8" of viewing area. No storage below display area.</p> <p>HALF VISION CASE 79 1/2"L x 20 7/16"W x 42"H Includes one plexi-glass shelf with adjustable brackets and 14 1/2" of viewing area.</p> <p>CORNER SHOW CASE Includes an area for storage below the display surface and has 12 1/4" of viewing area.</p>						
<p>All showcases are 42" high and include a lightbar mounted inside the top front edge and a sliding door with lock on the back.</p> <p>Electrical service for lightbar must be arranged through the facility.</p>						
TOTAL COST						
<p>Sub-Total _____ + Tax (6%) _____ = TOTAL _____</p>						

Don't see what you need?
Please call an Exhibitor Services Representative @ 404-253-6494.

carpet



When it comes to making your exhibit stand out on the show floor, we have you covered. Freeman offers several color options in both classic and prestige carpet designed to fit the requirements of your exhibit space.

- Freeman uses only colorfast carpet, making it a consistent, matching shade every time.
- Freeman's carpet is manufactured with recycled material.
- All of our carpet padding is manufactured with 90–95% recycled foam and is 100% recyclable.

prestige CARPET

Freeman's prestige carpet combines plush comfort with durable soil and stain resistance, perfect for high-traffic areas. Five popular colors are available in a luxurious 40-ounce weight and all nine designer colors are available in a 28-ounce weight.

Freeman's prestige carpet packages include new, 10-foot-wide carpet, delivery, Visqueen covering, installation, carpet tape, carpet removal and all carpet material handling fees. Price includes environmentally friendly disposal of carpet after usage. Foam carpet padding is available for a minimal fee. If you have a large order, please contact us to see if volume discounts may apply.

custom options

Prestige carpets can also be customized to fit your exhibit needs with unique logos, patterns and borders. Call the phone number on the Quick Facts for assistance.



*black**



cardinal



*charcoal**



cream



*gray pearl**

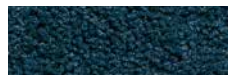

*navy**



toast



wedgewood



*white**

**Colors available in both 28 oz. and 40 oz.*

classic CARPET

custom cut

Freeman classic carpet is available in a range of colors and includes delivery, Visqueen covering, installation, carpet tape, carpet removal and all carpet material handling fees. Foam carpet padding is available for a minimal fee. If you have a large order, please contact us to see if volume discounts may apply.

standard cut

Our classic carpet comes in a variety of sizes. Prices include delivery, installation, carpet tape, carpet removal and all carpet material handling fees. Foam carpet padding and Visqueen covering are available for a minimal fee.



black



blue



gray



green



latte



midnight blue



plum



red



red pepper



tuxedo

Actual colors may vary slightly.

FREEMAN

841 Joseph E Lowery Blvd N W
 Atlanta, GA 30318
 (404) 253-6494 Fax: (469) 621-5610
 FreemanAtlantaES@freemanco.com

ONLINE PRICE
 DISCOUNT PRICE
 DEADLINE DATE
 OCTOBER 14, 2016

INCLUDE THE FREEMAN METHOD OF
 PAYMENT FORM WITH YOUR ORDER

NAME OF SHOW: **PFA 57TH ANNUAL SYMPOSIUM AND EXPO / NOVEMBER 04 - 05, 2016**

COMPANY NAME: _____ BOOTH #: _____ BOOTH SIZE: _____ X

CONTACT NAME : _____ PHONE #: _____

E-MAIL ADDRESS : _____

For Assistance, please call (404) 253-6494 to speak with one of our experts.

- Orders received after the deadline or without payment will be charged the Standard price.
- All utility lines must be installed before carpet installation. Utilities should be ordered in advance.
- Pricing includes delivery, material handling, installation and removal.

All carpets, padding and plastic covering contain recycled content and are recyclable.

For fast, easy ordering, go to www.freemanco.com/store

10' CLASSIC CARPET , PADDING & PLASTIC COVERING

CHOOSE YOUR CARPET COLOR:

- Black Blue Gray Green Latte Midnight Blue Plum Red Red Pepper Tuxedo

Qty	Description	Online Price	Discount Price	Standard Price	Total
_____	10' x 10' Classic Carpet	\$ 275.00	\$ 302.50	\$ 385.00	_____
_____	10' x 20' Classic Carpet	\$ 550.00	\$ 605.00	\$ 770.00	_____
_____	10' x 30' Classic Carpet	\$ 825.00	\$ 907.50	\$ 1,155.00	_____
_____	10' x 40' Classic Carpet	\$ 1,100.00	\$ 1,210.00	\$ 1,540.00	_____
_____	10' x 10' Carpet Padding - Single Layer.....	\$ 76.00	\$ 85.00	\$ 105.00	_____
_____	10' x 20' Carpet Padding - Single Layer.....	\$ 152.00	\$ 170.00	\$ 210.00	_____
_____	10' x 30' Carpet Padding - Single Layer.....	\$ 228.00	\$ 255.00	\$ 315.00	_____
_____	10' x 40' Carpet Padding - Single Layer.....	\$ 304.00	\$ 340.00	\$ 420.00	_____
_____	10' x 10' Carpet Padding - Double Layer.....	\$ 152.00	\$ 170.00	\$ 210.00	_____
_____	10' x 20' Carpet Padding - Double Layer.....	\$ 304.00	\$ 340.00	\$ 420.00	_____
_____	10' x 30' Carpet Padding - Double Layer.....	\$ 456.00	\$ 510.00	\$ 630.00	_____
_____	10' x 40' Carpet Padding - Double Layer.....	\$ 608.00	\$ 680.00	\$ 840.00	_____
_____	Plastic Covering (price per sq. ft.).....	\$.48	\$.55	\$.65	_____

9' CLASSIC CARPET , PADDING & PLASTIC COVERING

CHOOSE YOUR CARPET COLOR:

- Black Blue Gray Green Latte Midnight Blue Plum Red Red Pepper Tuxedo

Qty	Description	Online Price	Discount Price	Standard Price	Total
_____	9' x 10' Classic Carpet	\$ 176.35	\$ 194.00	\$ 246.90	_____
_____	9' x 20' Classic Carpet	\$ 351.30	\$ 386.45	\$ 491.80	_____
_____	9' x 30' Classic Carpet	\$ 527.40	\$ 580.15	\$ 738.35	_____
_____	9' x 40' Classic Carpet	\$ 701.90	\$ 772.10	\$ 982.65	_____
_____	9' x 10' Carpet Padding - Single Layer.....	\$ 68.40	\$ 76.50	\$ 94.50	_____
_____	9' x 20' Carpet Padding - Single Layer.....	\$ 136.80	\$ 153.00	\$ 189.00	_____
_____	9' x 30' Carpet Padding - Single Layer.....	\$ 205.20	\$ 229.50	\$ 283.50	_____
_____	9' x 40' Carpet Padding - Single Layer.....	\$ 273.60	\$ 306.00	\$ 378.00	_____
_____	9' x 10' Carpet Padding - Double Layer.....	\$ 136.80	\$ 153.00	\$ 189.00	_____
_____	9' x 20' Carpet Padding - Double Layer.....	\$ 273.60	\$ 306.00	\$ 378.00	_____
_____	9' x 30' Carpet Padding - Double Layer.....	\$ 410.40	\$ 459.00	\$ 567.00	_____
_____	9' x 40' Carpet Padding - Double Layer.....	\$ 547.20	\$ 612.00	\$ 756.00	_____
_____	Plastic Covering (price per sq. ft.).....	\$.48	\$.55	\$.65	_____

9' carpet is laid toward the front edge, leaving 1' at the back of the booth for access to utility ports.

TOTAL COST		
Sub- Total	+	6% Tax
	=	Total Cost

FREEMAN standard size carpet

Take advantage of the Online price by ordering at www.freemanco.com/store before OCTOBER 14, 2016

F R E E M A N

841 Joseph E Lowery Blvd N W
Atlanta, GA 30318
(404) 253-6494 Fax: (469) 621-5610
FreemanAtlantaES@freemanco.com

ONLINE PRICE
DISCOUNT PRICE
DEADLINE DATE
OCTOBER 14, 2016

INCLUDE THE FREEMAN METHOD OF
PAYMENT FORM WITH YOUR ORDER

NAME OF SHOW: **PFA 57TH ANNUAL SYMPOSIUM AND EXPO / NOVEMBER 04 - 05, 2016**

COMPANY NAME: _____ BOOTH #: _____ BOOTH SIZE: _____ X

CONTACT NAME : _____ PHONE #: _____

E-MAIL ADDRESS : _____

For Assistance, please call (404) 253-6494 to speak with one of our experts.

- Guaranteed new, high-quality carpet.
- Orders received after the deadline or without payment will be charged the Standard price and are subject to availability.
- Prestige and Custom Cut Classic Carpet are subject to a 100% cancellation charge.
- All utility lines must be installed before carpet installation. Utilities should be ordered in advance.

All carpets, padding and plastic covering contain recycled content and are recyclable.

For fast, easy ordering, go to www.freemanco.com/store

CUSTOM CUT CLASSIC CARPET - includes plastic covering, delivery, material handling, installation and removal

- Order Custom Cut Classic Carpeting by the sq. ft. if your size is not listed on the standard size order form.

Sample: Booth Size: 10 x 25 = 250 sq. ft. @ \$ **2.90**

CHOOSE YOUR CARPET COLOR - 16 oz. Carpet:

- Black Blue Gray Green Latte Midnight Blue Plum Red Red Pepper Tuxedo

16 oz. Carpet Rental - Price per square foot (100 sq. ft. minimum)

Per sq. ft.	Booth Size: _____ x _____ = _____ sq. ft. @	Online Price	Discount Price	Standard Price	Total
		\$ 2.90	\$ 3.20	\$ 4.05	_____

PRESTIGE CARPET - includes plastic covering, delivery, material handling, installation and removal

CHOOSE YOUR CARPET COLOR - 28 oz. Carpet:

- Black Cardinal Charcoal Cream Gray Pearl Navy Toast Wedgewood White

28 oz. Carpet Rental - Price per sq. ft. (100 sq. ft. minimum)

	Booth Size: _____ x _____ = _____ sq. ft. @	Online Price	Discount Price	Standard Price	Total
1 - 700 sq. ft.		\$ 3.35	\$ 3.70	\$ 4.70	_____
Over 700 sq. ft.		\$ 3.05	\$ 3.35	\$ 4.25	_____

CHOOSE YOUR CARPET COLOR - 40 oz. Carpet:

- Black Charcoal Gray Pearl Navy White

40 oz. Carpet Rental - Price per sq. ft. (100 sq. ft. minimum)

	Booth Size: _____ x _____ = _____ sq. ft. @	Online Price	Discount Price	Standard Price	Total
1 - 700 sq. ft.		\$ 4.10	\$ 4.50	\$ 5.75	_____
Over 700 sq. ft.		\$ 3.75	\$ 4.15	\$ 5.25	_____

CARPET PADDING - includes delivery, material handling, installation and removal

- Order Carpet Padding by the sq. ft. if your size is not listed on the standard size order form.

Sample: Booth Size: 10 x 25 = 250 sq. ft. @ \$ **.76**

Qty	Description	Price per sq. ft. (90 sq. ft. minimum)	Online Price	Discount Price	Standard Price	Total
_____	Carpet Padding -1/2" (90 - 700 sq. ft.)		\$.76	\$.85	\$ 1.05	_____
_____	Carpet Padding-1/2" (Over 700 sq. ft.)		\$.53	\$.60	\$.75	_____
_____	Double Carpet Padding - 1/2" (90 - 700 sq. ft.)		\$ 1.52	\$ 1.70	\$ 2.10	_____
_____	Double Carpet Padding -1/2" (Over 700 sq. ft.)		\$ 1.06	\$ 1.15	\$ 1.50	_____

TOTAL COST		
_____	+	_____
Sub- Total		6% Tax
	=	_____
		Total Cost

cut to size carpet

FREEMAN

Take advantage of the Online price
by ordering at www.freemanco.com/store
before OCTOBER 14, 2016

F R E E M A N

841 Joseph E Lowery Blvd N W
 Atlanta, GA 30318
 (404) 253-6494 Fax: (469) 621-5610
 FreemanAtlantaES@freemanco.com

INCLUDE THE FREEMAN METHOD OF PAYMENT FORM WITH YOUR ORDER

NAME OF SHOW: **PFA 57TH ANNUAL SYMPOSIUM AND EXPO / NOVEMBER 04 - 05, 2016**

COMPANY NAME: _____ BOOTH #: _____ BOOTH SIZE: _____ X

CONTACT NAME : _____ PHONE #: _____

E-MAIL ADDRESS : _____

For Assistance, please call (404) 253-6494 to speak with one of our experts.

For fast, easy ordering, go to www.freemanco.com/store

CLEANING SERVICES

- Prices are based on total square footage of booth regardless of area to be cleaned.
- 100 sq. ft. minimum.
- Our exclusive cleaning contract for this show will not permit other service contractors, including exhibitor appointed contractors to provide this service.
- **Show Site Prices will apply to all cleaning orders placed at show site.**

VACUUMING (per sq. ft. - 100 sq. ft. minimum)

Qty (sq. ft.)	Part #	Description	Advance Price	Show Site Price	Total
---------------	--------	-------------	---------------	-----------------	-------

• Includes emptying of your booth's wastebasket(s) at the time of vacuuming.

_____	610100	Booth Vacuuming - One Time60	.85	_____
_____	610200	Booth Vacuuming - 2 Days90	1.25	_____

SHAMPOOING (per sq ft - 100 sq ft minimum)

Qty (sq. ft.)	Part #	Description	Advance Price	Show Site Price	Total
---------------	--------	-------------	---------------	-----------------	-------

_____	630100	Shampoo Carpet - One Time80	1.10	_____
_____	630200	Shampoo Carpet - 2 Days	1.40	1.95	_____

PORTER SERVICE (per day)

Qty (# days)	Part #	Description	Advance Price	Show Site Price	Total
--------------	--------	-------------	---------------	-----------------	-------

• Includes emptying of your booth's wastebasket(s) and policing of your exhibit area at two-hour intervals during show hours.

_____	620500	Exhibit Area / Under 500 sq.ft.	100.10	140.15	_____
_____	6201500	Exhibit Area / 501 - 1,500 sq. ft.	140.30	196.40	_____
_____	6202500	Exhibit Area / 1,501 - 2,500 sq. ft.	177.00	247.80	_____
_____	6203500	Exhibit Area / Over 2,500 sq.ft.....	Call for Quote		

TOTAL COST				
_____	+	_____	=	_____
Sub-Total		6 %Tax		Total Cost

FREEMAN cleaning



RENTAL exhibits



Package 1

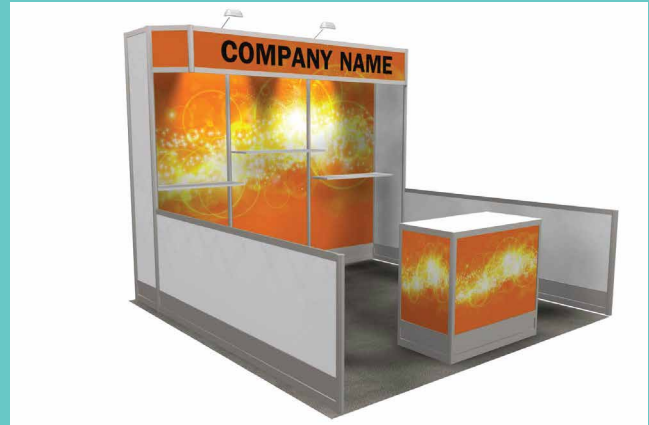

Package 1 upgraded with graphics and cabinet



Package 2



Package 2 upgraded with graphics and cabinet



Package 3



Package 3 upgraded with graphics and cabinet



Package 4



Package 4 upgraded with graphics and cabinet



Package 5



Package 5 upgraded with graphics and cabinet



Package 6



Package 6 upgraded with graphics and cabinet

* All exhibits include: installation & dismantle of exhibit, material handling of exhibit, classic carpet with nightly vacuuming, 2 arm lights (per 10' unit), power (500 watts) for lights ONLY and labor to hang arm lights.

Questions? All packages can be customized or modified. To speak with an Exhibitor Sales specialist, call the number listed on Quick Facts. For fast easy ordering, go to www.freemanco.com.

Color Options - Classic Carpet

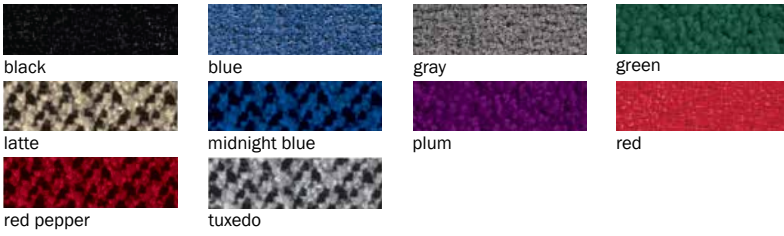

Color Options - Fabric and Hardwall Panels

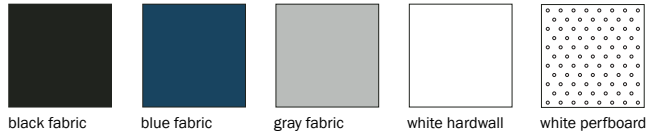

Upgraded Color Options - Prestige Carpet

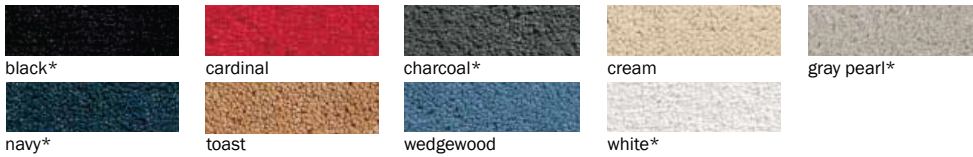

*Colors available in both 28 oz. and 40 oz.

Questions?

All packages can be customized or modified. To speak with an Exhibitor Sales specialist, call the number listed on Quick Facts. For additional custom examples click on the link below.

Upgrade options available. Sample upgrades shown below.



Slatwall & Shelves



Black Metal

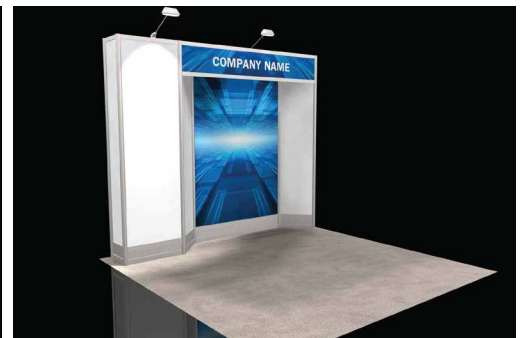

Graphics & Custom Logo



Cabinets & Counters



Colored Panels

To view additional custom designs



www.freemanco.com/customexhibits

FREEMAN

841 Joseph E Lowery Blvd N W
 Atlanta, GA 30318
 (404) 253-6494 Fax: (469) 621-5610
 FreemanAtlantaES@freemanco.com

DISCOUNT PRICE
 DEADLINE DATE
 OCTOBER 14, 2016

INCLUDE THE FREEMAN METHOD OF
 PAYMENT FORM WITH YOUR ORDER

NAME OF SHOW: **PFA 57TH ANNUAL SYMPOSIUM AND EXPO / NOVEMBER 04 - 05, 2016**

COMPANY NAME: _____ BOOTH #: _____ BOOTH SIZE: _____ X

CONTACT NAME : _____ PHONE #: _____

E-MAIL ADDRESS : _____

For Assistance, please call (404) 253-6494 to speak with one of our experts.

For fast, easy ordering, go to www.freemanco.com/store

All Exhibits Include: installation & dismantle of exhibit, material handling of exhibit, 9' x 10' or 9' x 20' classic carpet with nightly vacuuming, 2 arm lights (per 10' unit), power (500 watts) for lights ONLY and labor to hang arm lights.

To place your order, please check the appropriate box and complete the remaining selections at the bottom of the form.

RENTAL EXHIBITS

		Discount Price	Standard Price		Discount Price	Standard Price	
Package 1	<input type="checkbox"/> 10' x 10'	2,700.80	3,781.10	<input type="checkbox"/> 10' x 20'	5,401.50	7,562.10	_____
Package 2	<input type="checkbox"/> 10' x 10'	1,753.40	2,454.75	<input type="checkbox"/> 10' x 20'	3,506.80	4,909.50	_____
Package 3	<input type="checkbox"/> 10' x 10'	2,282.55	3,195.55	<input type="checkbox"/> 10' x 20'	4,565.20	6,391.30	_____
Package 4	<input type="checkbox"/> 10' x 10'	2,069.50	2,897.30	<input type="checkbox"/> 10' x 20'	4,138.95	5,794.55	_____
Package 5	<input type="checkbox"/> 10' x 10'	2,011.05	2,815.45	<input type="checkbox"/> 10' x 20'	4,022.25	5,631.15	_____
Package 6	<input type="checkbox"/> 10' x 10'	2,102.90	2,944.05	<input type="checkbox"/> 10' x 20'	4,205.75	5,888.05	_____

CHOOSE YOUR PANEL

- Black Fabric Blue Fabric Gray Fabric White Hardwall White Perfboard

CARPET

Our Classic Carpet and nightly vacuuming are included in the price of your Rental Exhibit. The following colors are available:

Check color choice

- Black Blue Gray Green Latte
 Midnight Blue Plum Red Red Pepper Tuxedo

You may want to add padding or upgrade your carpet to one of our 15 designer colors in our PRESTIGE carpet line. Now available in 28 oz. and 40 oz. weight. Refer to our enclosed Carpet order form for color selections and pricing.

LIGHTING

Each Rental Exhibit includes 2 Arm Lights (per 10' unit).

Note: Power and labor to hang the lights are included in our standard rental exhibit package price. Power consumption not to exceed 500 Watts.

Additional power must be ordered separately.

HEADER IDENTIFICATION SIGN

Indicate which color lettering you would like. We have a wide variety of standard colors available:

- Black Blue Brown Burgundy PMS Color _____
 Red Teal White Dark Green Font Type _____

Indicate exactly how you want your company name to appear:

*Unless font type is indicated, Helvetica will be used.

ENHANCE YOUR EXHIBIT

Enhance your exhibit and have an Exhibitor Sales Specialist contact you for pricing by checking any of the following boxes:

- Slatwall & Shelves Cabinets & Counters Specialty Colored Metal Recyclable Graphics
 Colored Panels Creating a Custom Exhibit Graphics & Custom Logo White Eco-Board

The product offered has recyclable content or has eco-friendly attributes and is 100% recyclable according to manufacturer's specifications.

TOTAL COST		
_____	+	_____ = _____
Sub-Total		6 % Tax Total Cost

FREEMAN

841 Joseph E Lowery Blvd N W
 Atlanta, GA 30318
 (404) 253-6494 Fax: (469) 621-5610
 FreemanAtlantaES@freemanco.com

DISCOUNT PRICE
 DEADLINE DATE
 OCTOBER 14, 2016

INCLUDE THE FREEMAN METHOD OF
 PAYMENT FORM WITH YOUR ORDER

NAME OF SHOW: **PFA 57TH ANNUAL SYMPOSIUM AND EXPO / NOVEMBER 04 - 05, 2016**



COMPANY NAME: _____ BOOTH #: _____ BOOTH SIZE: **X**

CONTACT NAME : _____ PHONE #: _____

E-MAIL ADDRESS : _____

For Assistance, please call (404) 253-6494 to speak with one of our experts.

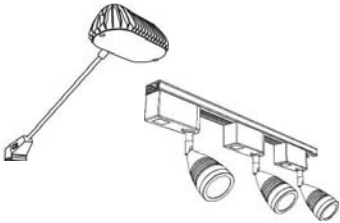
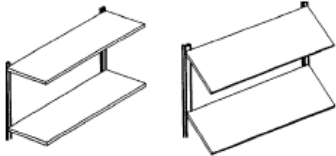
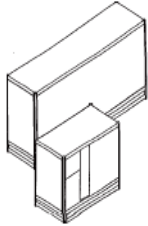
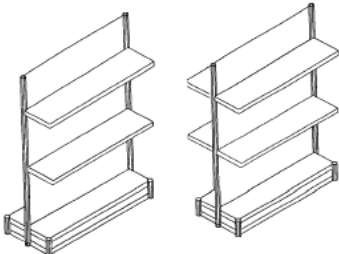
For fast, easy ordering, go to www.freemanco.com/store
ACCESSORIES FOR RENTAL UNITS

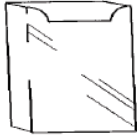
LIGHTS (use only on rentals) 	SHELVES (use only on rentals) 	CABINETS 
GONDOLAS 	RADIUS CABINET (does not have doors) 	LITERATURE POCKETS 

Qty	Part #	Description	Discount Price	Standard Price	Total
LIGHT FIXTURES					
(electrical service & labor to install lights not included)					
___	172512	Arm Light	122.30	171.20	_____
___	172514	4' Tracklight (3 lights)	377.00	527.80	_____
___	17252	Halogen Light	122.30	171.20	_____

CABINETS & LOCKS					
Cabinets					
<input type="checkbox"/> Black Fabric <input type="checkbox"/> Blue Fabric <input type="checkbox"/> Gray Fabric <input type="checkbox"/> White PVC					
___	17305	1M x ½M x 36" High.....	417.40	584.35	_____
___	17306	1M x ½M x 42" High.....	417.40	584.35	_____
___	17308	2M x ½M x 36" High.....	670.30	938.40	_____
___	17309	2M x ½M x 42" High.....	670.30	938.40	_____
___	173010	1M Radius x ½M x 36" High.	619.50	867.30	_____
___	173011	1M Radius x ½M x 42" High..	619.50	867.30	_____
(Radius Cabinets do not have doors)					
___	17301	Cabinet Lock	N/A	N/A	_____
Inside Shelves Available Quoted on Request					

Qty	Part #	Description	Discount Price	Standard Price	Total
GONDOLAS					
Gondolas					
<input type="checkbox"/> Blue Fabric <input type="checkbox"/> Gray Fabric <input type="checkbox"/> Perboard <input type="checkbox"/> White PVC					
___	174541	Single Sided 1M x 4' High...	378.50	529.90	_____
___	174542	Double Sided 1M x 4' High..	505.45	707.65	_____
___	174581	Single Sided 1M x 8' High...	626.00	876.40	_____
___	174582	Double Sided 1M x 8' High..	834.80	1,168.70	_____

SHELVES					
___	17201	1M Straight (37" x12")	75.85	106.20	_____
___	17206	1M Angled (37" x 12")	100.10	140.15	_____

LITERATURE POCKETS					
___	174015	For 8½ x 11 Literature	37.10	51.95	_____

TOTAL COST					
_____	+	_____	=	_____	_____
Sub-Total		6% Tax		Total Cost	

Don't see what you need?
 Please call an Exhibitor Sales Specialist at (404) 253-6494.

** Remember to make a selection for items with checkboxes. Otherwise, a selection will be made for you.*

TOTALFLEX[®]

By Freeman

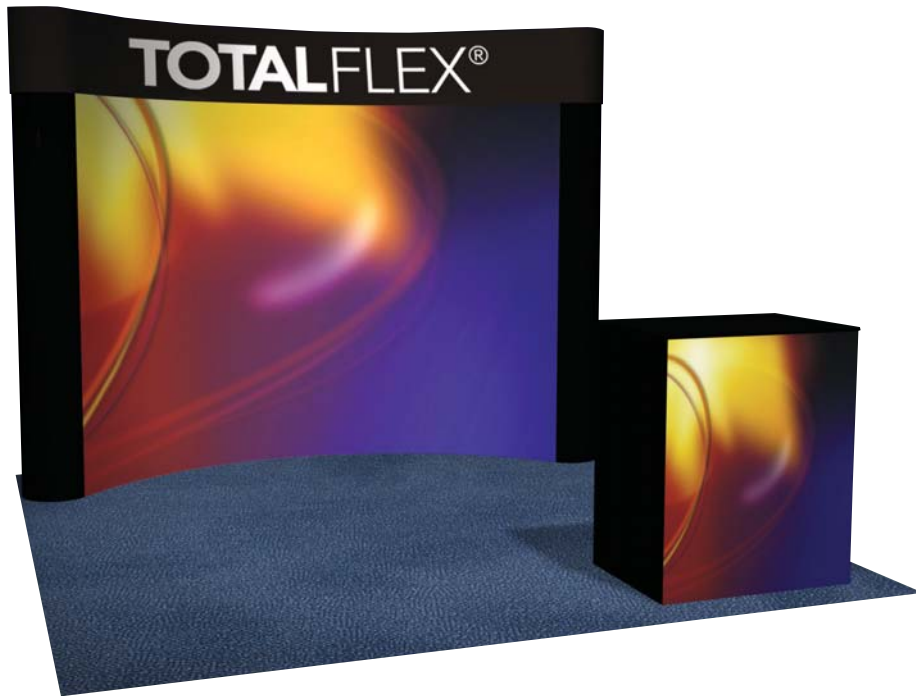

Available to rent or purchase, TotalFlex provides more options for configuring exhibits to fit your space, budget and vision. This pop-up display is versatile, lightweight, portable, durable, and needs just minutes and no tools to set up.

- Cases easily convert into a podium.
- Velcro compatible fabric panels available in a wide selection of colors.
- Compatible with shelves, lights and other innovative trade show accessories.
- Freeman can produce high-resolution digital graphics in virtually any size as well as photomural panels to enhance your exhibit's appearance.*
- Available in a variety of sizes for rental or purchase, including a table top version shown below.
- All TotalFlex units include Installation & Dismantle of display system, material handling of display system, Classic Carpet with nightly vacuuming, 200 watt halogen lights (one light for the table top unit, two lights for the floor unit) as well as power and labor to hang them.

floor units

8'w x 8'h Floor Standing Unit
10'w x 8'h Floor Standing Unit

table top units

6'w x 40"h Table Top Unit
8'w x 40"h Table Top Unit

**Graphic design elements are priced separately and not included with exhibit order.*



FREEMAN

841 Joseph E Lowery Blvd N W
Atlanta, GA 30318
(404) 253-6494 Fax: (469) 621-5610
FreemanAtlantaES@freemanco.com

DISCOUNT PRICE
DEADLINE DATE
OCTOBER 14, 2016

INCLUDE THE FREEMAN METHOD OF
PAYMENT FORM WITH YOUR ORDER

NAME OF SHOW: **PFA 57TH ANNUAL SYMPOSIUM AND EXPO / NOVEMBER 04 - 05, 2016**

COMPANY NAME: _____ BOOTH #: _____ BOOTH SIZE: _____ X

CONTACT NAME : _____ PHONE #: _____

E-MAIL ADDRESS : _____

For Assistance, please call (404) 253-6494 to speak with one of our experts.

For fast, easy ordering, go to www.freemanco.com/store

TABLE TOP UNIT



RENTAL			QTY	TOTAL
Size	Discount Price	Standard Price		
40"H x 6'W	1,008.60	1,412.05	_____	_____
40"H x 8'W	1,177.10	1,647.95	_____	_____
PURCHASE*				
Size	Discount Price	Standard Price		
40"H x 6'W	1,253.25	1,754.55	_____	_____
40"H x 8'W	1,421.30	1,989.80	_____	_____

*Shipping Not Included

Rental Units Include:
Draped Table (select color below)
Classic Carpet 9' X 10' (select color below)
Installation & Dismantle of Exhibit
Material Handling of Exhibit
Nightly Vacuuming
1-200 Watt Halogen Light (Power (500 watts) for LIGHTS only and Labor to hang lights)

Purchase Units Include:
1-Case
One Time Installation & Dismantle

Header Identification Sign - (white with black text) Indicate copy below:

Fabric Panel Colors for All Units: Black Gray

Additional Fabric Panel Colors for Purchase Units Only:
 Blaze Red Blueberry Emerald Silver

***Other Colors Also Available for Purchase Units**
9' x 10' Classic Carpet: Black Blue Green Gray
 Latte Midnight Blue Plum Red Red Pepper Tuxedo

Table Drape:
 Black Blue Brown Dark Green Flax
 Gold Gray Plum Red White

FLOOR UNIT



RENTAL			QTY	TOTAL
Size	Discount Price	Standard Price		
8'H x 8'W	1,680.75	2,353.05	_____	_____
8'H x 10'W	2,011.05	2,815.45	_____	_____
PURCHASE*				
Size	Discount Price	Standard Price		
8'H x 8'W	2,824.40	3,954.15	_____	_____
8'H x 10'W	3,318.10	4,645.35	_____	_____

*Shipping Not Included

Rental Units Include:
Classic Carpet 9' X 10' (select color below)
Installation & Dismantle of Exhibit
Material Handling of Exhibit
Nightly Vacuuming
1-Podium - 8'H X 10'W unit only
2-200 Watt Halogen Lights (Power (500 watts) for LIGHTS only and Labor to hang lights)

Purchase Units Include:
2-Cases
One Time Installation & Dismantle
1-Podium - 8'H X 10'W unit only

Header Identification Sign - (white with black text) Indicate copy below:

Fabric Panel Colors for All Units: Black Gray

Additional Fabric Panel Colors for Purchase Units Only:
 Blaze Red Blueberry Emerald Silver

***Other Colors Also Available for Purchase Units**
9' x 10' Classic Carpet: Black Blue Green Gray
 Latte Midnight Blue Plum Red Red Pepper Tuxedo

All Classic carpet contain recycled content and are recyclable.

CUSTOM GRAPHIC / PHOTO PANELS

Our custom graphic panels can dramatically enhance your exhibit's appearance.

Please check the box to have an Exhibitor Sales Specialist contact you to assist in creating a unique exhibit.

OPTIONAL ACCESSORIES			RENTAL			PURCHASE			
Part #	Description	Qty	Discount Price	Standard Price	Total	Qty	Discount Price	Standard Price	Total
1715800	2-200 Watt Halogen Light Kit	_____	210.50	294.70	_____	_____	298.30	417.60	_____
1715801	1-200 Watt Halogen Light Kit	_____	109.55	153.35	_____	_____	215.75	302.05	_____
1715802	Straight Shelf	_____	85.65	119.90	_____	_____	150.60	210.85	_____
1715803	Angled Shelf	_____	85.65	119.90	_____	_____	150.60	210.85	_____

QUICK TIPS

* If shipping literature or products, material handling rates will apply.

* Order in advance to save time, money and ensure availability. **Orders received after the deadline date or without payment will be charged the Standard Price.**

PURCHASE UNITS TOTAL COST

Sub-Total + 6% Tax = Total Cost

RENTAL UNITS TOTAL COST

Sub-Total + 6% Tax = Total Cost



digital graphics



creating visual excitement

Quality graphics contribute significantly to the impact of your exhibit. Vivid colors and sharp images attract attention, build traffic, and communicate messages more effectively. Freeman has invested in the latest printing technology and has the skills to provide you with the finest digital graphic reproduction available.

state-of-the-art capabilities

Freeman can provide four-color, photo-quality, high-resolution digital printing in virtually any size for banners, signage, exhibit graphics, and more. Each Freeman location has stand-alone printing capabilities, and all are supported by the Corporate Graphics Center for special requirements. Last minute repairs and replacements are handled efficiently through our nationwide resources.

superior quality control

Electronic file transfer, in-house printing, and company-wide standardization of procedures allow us to control quality, cost and scheduling for our customers on a nationwide basis.

depth of resources

- VUTEK™ and Salsa printers provide large format, four-color, high-resolution digital printing of single and double-sided banners up to 10' wide and virtually any size with seams.
- Encad printers provide digital processing of banners up to 5' wide without seams.
- All Freeman operations use the same printers, software, ink, adhesives, and laminates for continuity.
- Seaming, grommeting, lamination, and mounting are handled in-house.
- A variety of fabrics are available, including nylon, vinyl, and mesh materials.
- Computer-aided graphic design for your assistance.

freeman specializes in the digital graphic reproduction and installation of:

- Suspended banners
- Logo reproduction
- Accent graphic photo panels
- Backlit displays and murals
- Large format signage and banners
- four-color carpet image printing

questions?

Call customer service at the number listed on Quick Facts. For fast, easy ordering, go to www.freemanco.com.

FREEMAN

841 Joseph E Lowery Blvd N W
Atlanta, GA 30318
(404) 253-6494 Fax: (469) 621-5610
FreemanAtlantaES@freemanco.com

DISCOUNT PRICE
DEADLINE DATE
OCTOBER 14, 2016

INCLUDE THE FREEMAN METHOD OF
PAYMENT FORM WITH YOUR ORDER

NAME OF SHOW: **PFA 57TH ANNUAL SYMPOSIUM AND EXPO / NOVEMBER 04 - 05, 2016**

COMPANY NAME: _____ BOOTH #: _____ BOOTH SIZE: X

CONTACT NAME: _____ PHONE #: _____

E-MAIL ADDRESS: _____

For Assistance, please call (404) 253-6494 to speak with one of our experts.

For fast, easy ordering, go to www.freemanco.com/store

GRAPHICS

To order your graphics, complete this order form and attach your sign copy or electronic file.

Please see artwork guidelines for electronic files on page 2 of this form.

Note: All graphics are subject to a 100% Cancellation Charge.

DIGITAL GRAPHICS

Freeman has the capabilities to provide you with the finest digital graphic reproduction available. Capabilities include four-color, photo-quality, high-resolution digital printing virtually any size for banners, signage, exhibit graphics and more.

_____ L X _____ W = _____ sq.ft.

sq. ft. _____ \$ 20.55 per sq. ft. discount price
x or = \$ _____
\$ 30.85 per sq. ft. standard price

- Minimum order per graphic 9 sq. ft. (1296 sq. in.)
- Double sq. ft. for double-sided graphics
- Round sq. ft. to next whole increment
- File conversion, retouching, cloning or color correcting may incur additional labor charges. (See reverse side for graphic guidelines.)

LARGE DIGITAL GRAPHICS

Please call an Exhibitor Sales Specialist for price quotes on graphics over 80 sq. ft.

File Information:

Electronic File Name _____

Application _____

PMS Colors _____

Backing Material:

- | | |
|---|--|
| <input type="checkbox"/> Freeman Foam (Foamcore) | <input type="checkbox"/> Masonite |
| <input type="checkbox"/> Freeman PVC (PVC) | <input type="checkbox"/> Plexi |
| <input type="checkbox"/> Freeman HD Foam (Gatorfoam) | <input type="checkbox"/> Freeman Honeycomb (Eco-Board) |
| <input type="checkbox"/> Freeman Polyfoam (Ultra Board) | <input type="checkbox"/> Other |

The product offered has recycled content or has eco-friendly attributes and is 100% recyclable according to the manufacturer's specifications.

Vertical _____ Horizontal _____ Use Your Judgment For Sign Layout _____

Special Instructions

STANDARD SIZES

CHOOSE YOUR SIZE:

QTY.	Discount Price	Standard Price	TOTAL
7" x 11"	@ 58.00	87.00 =	_____
7" x 22"	@ 60.05	90.10 =	_____
7" x 44"	@ 66.35	99.55 =	_____
9" x 44"	@ 87.60	131.40 =	_____
11" x 14"	@ 61.80	92.70 =	_____
14" x 22"	@ 87.60	131.40 =	_____
14" x 44"	@ 99.55	149.35 =	_____
22" x 28"	@ 104.60	156.90 =	_____
28" x 44"	@ 158.55	237.85 =	_____
20" x 60"	@ 212.90	319.35 =	_____

(white only)

Note: File conversion, retouching, cloning or color may incur additional labor charges. (See reverse side for graphic guidelines.)

INDICATE YOUR SIGN COPY HERE:

* Please feel free to attach additional sign copy on separate page.

Vertical

Horizontal

Use Your Judgment For Sign Layout

Background Color: _____

Lettering Color: _____

TOTAL COST

Sub-Total + 6 % Tax = Total Cost

graphics

FREEMAN

CUSTOMER GUIDELINES FOR SUBMITTING GRAPHICS ARTWORK

Our goal is to provide you with the best possible quality graphics for your event or exhibit. You can help us in that effort by providing digital art files using the following guidelines. If you are sending us completed, print-ready files, please pass the following information on to your graphics designer or art department. Two overall considerations for submitting acceptable artwork involves proper resolution or size of the file to avoid poor quality images, and proper color matching information and proofs to ensure accurate color reproduction.

PLEASE PROVIDE THE FOLLOWING WHEN SUBMITTING ART

RASTER ART (photos, logos containing any continuous tone images):

- Art submitted at 1:1 (100%), resolution should be no less than 60 dpi (100 dpi preferred)
- Art submitted at 2:1 (50%), resolution should be no less than 120 dpi (200 dpi preferred)
- Art submitted at 4:1 (25%), resolution should be no less than 240 dpi (400 dpi preferred)

VECTOR ART:

- Logos should be vector and have outlined fonts (if provided as bitmap, please use high-res images)

FONTS and LINKS

- Supply all fonts used in your design (zip Mac fonts). If unsure how to collect fonts, convert them to outlines
- Supply all links used in your document. Use packaging feature if available. If unsure how to collect links, embed them in the file when saving.

COLOR

- If PMS color matching is required, please use original Pantone + Solid Coated swatches in your artwork. Modifying Pantone names will result in printing default color (CMYK)
- CMYK artwork will be produced "As Is". Our color output is balanced and vibrant.
- Convert RGB art to CMYK if possible.
- If you are sending Certified Color Proofs (Gracol, Swop, Fogra), please provide ICC file information used to print your samples. Best option would be to include ICC chart on your prints.

ARTWORK IN THE STRUCTURE

- Please note that any panels going in the metal frame will hide 1/4" of your art all the way around. If you have a continuous wall where individual panels are divided by metal, use 1.25" spacing in between each panel to account for gaps and the natural flow of the graphics.

ACCEPTABLE FILE SOFTWARE

We are capable of working with both PC and MAC based software, and can accept art created with the ADOBE Creative Suite - Illustrator, InDesign, and Photoshop

Always provide the following:

- Native files with fonts and links (zipped)
- High-res PDF-X/4 exports of the files

ACCEPTABLE FILE TYPES and SUPPORT FILES

NATIVE FILES:

- AI CLOUD (CC) file with Packaged supporting links and fonts. You may keep images linked but Packaging feature must be used.
- AI (CS6, CS5, CS4...) file with embedded links and outlined fonts
- EPS file with embedded links and outlined fonts
- INDD file with Packaged supporting links and fonts

PRINT FILES:

- High-res PDF-X/4 (preferred)
- AI with PDF content (choose this option when saving file)
- EPS files with embedded links and outlined fonts

RASTER OR BITMAP ART:

- Photoshop EPS (preferred, use 8-bit preview, Max, Quality JPG compression)
- PSD (make sure font layers are rasterized)
- TIFF, JPG (quality 8 and higher)

Mac users: Use Zip or Stuffit programs when submitting fonts other than OTF (Open Type Fonts)

WAYS TO SEND ARTWORK

• Files below 10 MB can be delivered via email. Larger files may be posted to Freeman's FTP site. You may get the password and other needed information from your Freeman service representative in order to post files. However, a hard copy proof and backup of the files on CD-Rom/DVD may be required to be sent via overnight delivery in addition to posting the electronic files. Please call (404) 253-6494 for assistance.

UNION JURISDICTIONS ATLANTA, GA

To assist you in planning for your participation in this upcoming exposition, we are certain you will appreciate knowing in advance that union labor may be required for certain aspects of your exhibit handling. To help you understand the jurisdiction of the various unions, we ask that you read the following:

EXHIBIT INSTALLATION AND DISMANTLING:

Currently we have an agreement with the Local Stagehand Union to provide labor for display installation and dismantling. Full time employees of the exhibiting companies, however, may set their own exhibits without the assistance of this Local. Any labor services that may be required beyond what your regular full time employees can provide must be rendered by the Union or an Exhibitor Appointed Contractor. Labor can be ordered in advance by returning the Display Labor Form, or at show site, at the Freeman Service Center.

MATERIAL HANDLING:

Exhibitors and full time employees of exhibiting companies may hand carry their own materials into the exhibit facility. However, the use or rental of dollies, flat trucks, pallet jacks or other mechanical equipment is not permitted. Freeman has the responsibility of receiving and handling all exhibit materials and crates, with the exception of items Exhibitors hand carry. Freeman will control access to the loading docks in order to provide for a safe and orderly move in/out. Unloading or reloading at the dock of any and all contracted carriers will be handled by Freeman.

Vehicles must not be left unattended at the loading areas. Any unattended vehicles will be towed at the owner's expense.

Fire Marshal regulations absolutely prohibit the storage of empty containers in the exhibit hall. Arrangements have been made with Freeman to store empty crates and containers. Please refer to the Material Handling section of this manual for information regarding the handling of empties, disposal of skids, etc.

GRATUITIES:

Tipping is expressly prohibited. This includes such practices as giving money, merchandise or other special consideration for services rendered. Please do not give breaks other than mid-morning and mid-afternoon, when the union has a scheduled 15 minute paid break. Meal breaks are one hour. Any attempt to solicit a gratuity by an employee should be reported immediately to the Exhibit Manager or a Freeman Supervisor.

SAFETY:

Standing on chairs, tables or other rental furniture is prohibited. This furniture is not engineered to support your standing weight. Freeman cannot be responsible for injuries or falls caused by the improper use of this furniture. If assistance is required in assembling your booth, please order the appropriate labor on the Display Labor Form and the necessary ladders and tools will be provided.

F R E E M A N



installation & dismantle

When it comes to installation and dismantling of exhibits, no one does it better than Freeman. With over 80 years of experience, our group of specialists is ready to assist you with all of your exhibit requests, from beginning to end.

Whether you choose to supervise or you need the assistance of a full-time Freeman employee, we can meet all your needs, from shipping and storage to emergency on-site repairs to basic installation and dismantling to support service coordination including electrical, furnishings and more. Freeman has the resources and the capabilities to help you have the most successful show experience possible.

installation and dismantling services available

Freeman will work closely with you to coordinate every phase of your trade show participation, including:

- Preplanning and budget consultation
- Support service coordination – electrical, furnishings, floral and more
- Shipping and storage management
- On-site supervisors with dedicated floor managers
- Skilled labor and technicians for installation and dismantling
- Full, in-house carpentry
- Graphics production
- Emergency repairs and refurbishing
- Postshow evaluations
- Multiple show coordination

Supervise any labor yourself, or if you need assistance, Freeman I&D experts will do it for you.

if you use Freeman staff

Exhibits can be set up prior to your arrival under the direction of Freeman I&D supervisors. We charge 30% of the total labor charge, with a minimum \$45 fee.

if you supervise yourself

Installation – Your labor supervisor must check in at the exhibitor service center to pick up laborers. Upon completion of work, your supervisor must return to the exhibitor service center to release the laborers. Start time is guaranteed only when labor is requested for the start of the working day.

Dismantling – When scheduling dismantling labor, be sure to allow time for empty containers to be returned to the booth after the close of your show. Start time is guaranteed only when labor is requested for the start of the working day.

questions?

For questions and assistance with labor estimates, call customer service at the number listed on Quick Facts.

For fast, easy ordering, visit us at www.freemanco.com.

F R E E M A N

841 Joseph E. Lowery Blvd N W
 Atlanta, GA 30318
 (404) 253-6494 Fax: (469) 621-5610
 FreemanAtlantaES@freemanco.com

INCLUDE THE FREEMAN METHOD OF PAYMENT FORM WITH YOUR ORDER

NAME OF SHOW: PFA 57TH ANNUAL SYMPOSIUM AND EXPO / NOVEMBER 04 - 05, 2016

COMPANY NAME _____ BOOTH #: _____

CONTACT NAME: _____ PHONE #: _____

E-MAIL ADDRESS _____

For Assistance, please call 404-253-6494 to speak with one of our experts.

For fast, easy ordering, go to www.freemanco.com/store

DISPLAY LABOR (One Hour Minimum per Worker)

Description	Advance Price	Show Site Price
Straight Time- 8:00 A.M. to 5:00 P.M. Monday through Friday	\$ 89.25	\$125.00
Overtime- 5:00 P.M. to 12:00 A.M. Monday through Friday All day Saturday & Sunday	\$ 134.00	\$187.75
Double Time- Midnight to 8:00 A.M. and recognized holidays.....	\$ 178.50	\$250.00

- **Show Site prices will apply to all labor orders placed at show site.**
- Price is per person/per hour.
- Start time guaranteed only at start of working day.
- One hour minimum per person - labor thereafter is charged in half (1/2) hour increments.
- Labor must be canceled in writing, 24 hours in advance to avoid a one (1) hour cancellation fee per worker.
- When scheduling dismantle labor, be sure to allow sufficient time for empty containers to be returned to your booth.
- Freeman supervised jobs will be completed at our discretion prior to show opening and before the hall must be cleared. **Please include setup plan/photo, special instructions & inbound shipping information with this order.**

INSTALLATION LABOR

Freeman Supervised Labor - Please complete the reverse side of this form.

- Installation of your exhibit will be completed at our discretion prior to show opening.
- The charge for this service is 30% of the total installation labor bill, with a minimum of \$45.00.

Emergency contact: _____ Phone Number: _____

Exhibitor Supervised Labor (Supervisor must check in at Service Desk to pick up labor)

Supervisor will be: _____ Phone Number: _____

Date	Start Time	No. of People	Approx. Hrs. per Person	Total Hrs.	Hourly Rate	Estimated Total Cost
_____	_____	_____	x _____ = _____	_____	@ \$ _____ = \$ _____	_____
_____	_____	_____	x _____ = _____	_____	@ \$ _____ = \$ _____	_____
_____	_____	_____	x _____ = _____	_____	@ \$ _____ = \$ _____	_____
Freeman Supervision (30%/\$45.00)						= \$ _____
Tax						= \$ (N/A)
Total Installation						= \$ _____

DISMANTLE LABOR

Freeman Supervised Labor - Please complete the reverse side of this form.

- Freeman is not responsible for product or literature that is not properly packed and labeled by exhibitor.
- The charge for this service is 30% of the total dismantle labor bill, with a minimum of \$45.00.

Emergency contact: _____ Phone Number: _____

Exhibitor Supervised Labor(Supervisor must check in at Service Desk to pick up labor)

Supervisor will be: _____ Phone Number: _____

Date	Start Time	No. of People	Approx. Hrs. per Person	Total Hrs.	Hourly Rate	Estimated Total Cost
_____	_____	_____	x _____ = _____	_____	@ \$ _____ = \$ _____	_____
_____	_____	_____	x _____ = _____	_____	@ \$ _____ = \$ _____	_____
_____	_____	_____	x _____ = _____	_____	@ \$ _____ = \$ _____	_____
Freeman Supervision (30%/\$45.00)						= \$ _____
Tax						= \$ (N/A)
Total Dismantle						= \$ _____

FREEMAN installation & dismantle labor

NAME OF SHOW: **PFA 57TH ANNUAL SYMPOSIUM AND EXPO / NOVEMBER 04 - 05, 2016**

COMPANY NAME: _____ BOOTH#: _____

CONTACT NAME: _____ PHONE#: _____

FREEMAN SUPERVISED LABOR

IN ORDER TO BETTER SERVE YOU - PLEASE COMPLETE THE FOLLOWING INFORMATION IF YOUR DISPLAY IS TO BE SET-UP AND/OR DISMANTLED BY FREEMAN I&D AND YOU WILL NOT BE PRESENT TO SUPERVISE THE INSTALLATION AND/OR DISMANTLE.

INBOUND SHIPPING & SET UP INFORMATION

Freight will be shipped to Warehouse _____ Show Site _____ Date Shipped _____

Total No. of: _____ Crates _____ Cartons _____ Fiber Cases _____

Setup Plan/Photo: Attached _____ To Be Sent With Exhibit _____ In Crate No. _____

Carpet: With Exhibit _____ Rented From Freeman _____ Color _____ Size _____

Electrical Placement: _____ Drawing Attached _____ Drawing With Exhibit _____

Electrical Under Carpet _____

Comments: _____

Graphics: With Exhibit _____ Shipped Separately _____

Comments: _____

Special Tools/Hardware Required: _____

OUTBOUND SHIPPING INFORMATION

SHIP TO: _____

METHOD OF SHIPMENT

- Freeman Exhibit Transportation:**
- Standard Ground
 - Air Freight Next Day 2nd Day Deferred Expedited
- Other (list carrier name & phone number):**
- Other Common Carrier: _____
 - Other Air Freight: _____
 - Van Line: _____

FREIGHT CHARGES

- Prepaid Collect
- Bill To: _____
- _____
- _____

In the event your selected carrier fails to show on final move-out day, please select one of the following options:

- Reroute via Freeman's choice
- Deliver back to Freeman warehouse at Exhibitor's expense.

PLEASE NOTE: Freeman is not responsible for product or literature that is not properly packed and labeled by exhibitor.



**EVENT TECHNOLOGY DEPARTMENT
EXHIBIT ORDER FORM**

Telephone: 770-303-3163

Fax: 770-303-3165

Convention Name: _____ Date: _____

Exhibitor: _____ Booth: _____

On-Site Contact: _____ Title: _____

Billing Address: _____

City: _____ State: _____ Zip Code: _____

Telephone: _____ Ext: _____ Fax: _____ Email: _____

Delivery Date/Time: _____ Pickup Date/Time: _____

<u>Quantity</u>	<u>Equipment</u>	<u>Daily Price</u>	<u>#Days</u>	<u>Total</u>
_____	50" Plasma Monitor	\$ 395.00	_____	_____
_____	T-1/High Speed Internet (1 st Connection)	\$ 250.00	_____	_____
_____	T-1/High Speed Internet (Additional Codes)	\$ 100.00	_____	_____
_____	Wireless Internet	\$ 80.00	_____	_____
_____	_____	_____	_____	_____

** To be connected to dedicated power provided by our Engineering Department*

Renaissance Event Technology has a complete inventory of A/V and Office Equipment available for rental, including Computers, Laser Printers and Fax Machines. Please call for individual needs and pricing.

Equipment Total: _____
 24% Service Charge: _____
 Sub Total: _____
 6% Sales Tax: _____
TOTAL: _____

Billing Information:

Master Account Number: _____

Hotel Room Number: _____

Hotel Room Number: _____

Check Number: _____

Cardholder Name: _____

Card Number: _____

Expiration Date: _____

Billing address (if different than above):

Terms: Exhibitor agrees to be at assigned booth at designated delivery time listed. Equipment will not be delivered unless a representative signs for the equipment. Exhibitor will be responsible for any lost or damaged equipment.

Name printed: _____

Date: _____

Signature: _____

Show Name: _____

Show Location: _____

Show Dates: _____



(770) 507-6777
FAX (770) 474-4676
plant@tfc-florist.com
www.tfc-florist.com

N•A•T•I•O•N•A•L
convention • plant • services

Exhibitor Name: _____ Booth Representative: _____
 Firm, Billing Name: _____ Purchase Order or Reference Number: _____
 Booth Number: _____ Credit Card #: _____
 Billing Address: _____ Expiration Date: _____ (MC, VISA, AM. EXP)
 City: _____ State: _____ Zip: _____ Name of Credit Card Holder as shown on card
 Show Decorator: _____
 Phone: _____ Fax: _____ Authorized Signature: _____
 Cell: _____ Email Address: _____

Please return completed form with payment to: P.O. Box 538, Rex, GA 30273 (770) 507-6777 (770) 474-4676 FAX
Please return overnight shipment with payments to: 121 Pine Dr., Stockbridge, GA 30281

For Design Help, Have A TLC Designer Visit Our Booth On The Following Date: _____ Time: _____

**FROM SIMPLE AND ELEGANT TO WILD AND COLORFUL!
LET A TLC DESIGNER CREATE THE PERFECT LOOK JUST FOR YOU!**

If you would like to specify color, size, type flowers, please do so below—*prices start at \$60.00.*

Qty _____ tropical flowers—Price \$ _____ each

Qty _____ Spring flowers—Price \$ _____ each

Color _____

Width _____ Height _____

Additional Request: _____



*Don't know what you want? Just want a splash of color?
Let TLC designers choose your fresh seasonal flowers!*

Qty _____ TLC pick my colors, size, type flowers \$50.00 ea

Visit www.tfc-florist.com for additional sample pictures.
For free design assistance, please call 770-507-6777 or email plant@tfc-florist.com with any questions.

TLC Designers can provide the following:

- **Water Features**
 - **Fountains**
 - **Ponds**
 - **Water falls**
 - **Swamps**
 - **Garden Areas**
 - Tropical :**
(beach scenes;
rain forests)
 - Seasonal:**
(Spring, Fall, Holiday)
 - Formal :**
(serenity garden,
English garden)
 - **Border Areas:**
 - Hedges**
(control flow)
 - Lawn or Golf**
(promotional)
 - Trees**
(privacy)
- Special services are Available for hospitality Suites, award banquets, And VIP room deliveries.**

COLORFUL POTS OF VIBRANT FLOWERS!



Mums—12"-18"H

\$20.00 each

Qty _____

White _____

Yellow _____

Lavender _____

Azaleas—12"H

\$35.00 each

Qty _____

White _____

Pink _____

Red _____

Bromeliads—12"-18"H

\$35.00 each

Qty _____

Purple _____ Red _____

Yellow _____ Orange _____

See next page for green plants.

FLORAL ORDER FORM

Ferns



Ferns
\$35.00 each

Qty ____

Ivy



Ivy—10”H x 10”W
\$35.00 each

Qty ____

Pothos



Pothos—12”H x 12”W
\$35.00 each

Qty ____



770) 507-6777
plant@tfc-florist.com
www.tfc-florist.com

FLORAL ORDER FORM

2' Green Plants



\$29.95 each Qty ____

3' Green Plants



\$39.95 each Qty ____

Standard 4' to 6' Green Plants



4' @ \$49.95 each Qty ____
5' @ \$59.95 each Qty ____
6' @ \$69.95 each Qty ____

7' H & Taller plants & Planters are available
Call 770-507-6777 for price/availability



Planters are 2 1/2' long.

Top-dressed with azalea (pictured)
Also available with mum
Choose flower color for flower choice.

For Top-dressing with fern & azalea
__ white, __ pink, __ red

For Top-dressing with fern & mum
__ white, __ yellow, __ lavender



4' @ \$125.00 each, Qty ____
5' @ \$135.00 each, Qty ____
6' @ \$145.00 each, Qty ____

Seasonal Flowering Plants
Call for Price & Availability

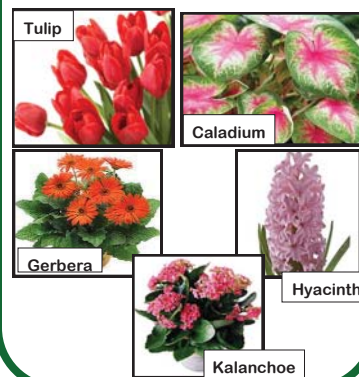

Rental price includes: Decorative container, top dressing, professional maintenance, installation and pick up. There is a one-time \$10.00 charge for **daily** floral delivery. **ALL ORDERS MUST BE PAID - IN - FULL PRIOR TO SHOW CLOSING.** We accept cash, company check, VISA, MASTERCARD, AMERICAN EXPRESS. Adjustments cannot be made after the close of the show. All rental items remain property of TLC Atlanta Convention Plant Services, Inc. **There is a restocking fee for orders cancelled less than 2 weeks prior to show opening.** **There is a 1.5% energy surcharge added to each order.** **Orders placed after the open of an event may be subject to a delivery fee.**

Order Cost Summary

Select Container (Included in rental cost)
__ Black __ White __ Wicker

Subtotal _____

____ % Sales Tax _____

Total _____

Chrome, Brass, Terra Cotta, & Other Containers are available. Please call 770-507-6777 for pricing.